



Mini and Whisper[®] Loaders INSTRUCTION MANUAL



May, 2007
IMS Company
10373 Stafford Road
Chagrin Falls, OH 44023-5296

Telephone: (440) 543-1615
Fax: (440) 543-1069
Email: sales@imscompany.com
Website: www.imscompany.com



TABLE OF CONTENTS

SAFETY PRECAUTIONS	4
UN-PACKING	5
SYSTEM DESCRIPTION	6
COMPONENT, MODEL & OPTION DESCRIPTIONS	7
Features and Benefits	7
Basic Components	7
Receiving Hopper	8
Tangential-Entry (TE) Inlet Options	8
Wear-Resist (WR) Inlet Option	8
Vibra-Pulse™ (VP) Option	8
Proportioning-Loader (PLVP) Option 9Powder (PR) Option	8
Motor Turbine	9
240-Volt Motor	9
Explosion-Proof Motor (XP) Option	10
Brushless Motor (BL2) Option	10
Proximity Switch	10
Filtration	11
Polyester/Felt Flat-Filter	11
DI-AC Media Flat-Filter	11
Pleated Cartridge Filter	11
Gaskets	11
Filters & Tubesheets	11
Motor	11
CONTROLLER	12
Control Panel	12



PLC Controller	12
Factory Settings	12
Quick-Start	12
Circuit Breaker	14
Service Indicator	14
MATERIAL PICK-UP	14
Pick-Up Lance	14
Hose	14
INSTALLATION	15
SEQUENCE OF OPERATION	16
MAINTENANCE	17
Motor	17
Motor Replacement	17
Motor Brush Replacement	17
Filter Maintenance	18
Flat Filters	18
Cartridge Filters	19
WIRING DIAGRAMS	20
Diagram for WL1250/1500	20
Diagram for WL1250/1500 PLVP	21
Diagram for PL1250/1500 PR/VP	22
TROUBLEHOOTING	23
SPARE PARTS	24
NOTES	26
Serial Number Log	26
ADDENDUMS	26
RETURNS	27
PARTS LIST BY MODEL	28

BEFORE YOU BEGIN

- ✓ Check all Packaging materials Upon Receipt of Equipment
- 📖 Read All Instructions PRIOR to Operating this Equipment
- 📞 Call our Factory for Support or Start-up Assistance
- 📅 Review this Manual periodically to maintain full product awareness

IMS maintains stock on a large inventory of standard products and replacement parts to support customer service. Whether replacement parts, components or a complete turn-key conveying system; let IMS handle your next project. Contact IMS' Sales Department, Customer Service or a local representative if you're interested in upgrades, system expansion or maintenance programs for your present system.

This OMM includes safety precautions, installation steps, maintenance procedures and supporting engineering drawings to assist both production supervisors and facilities maintenance engineers. Please take the necessary time to read this document in its entirety prior to operating the equipment.

A note to Plant Supervisors: Ensure that all personnel assigned to the operation and maintenance of this equipment has been fully trained. Periodically revisit this OMM to refresh & enforce your knowledge base of the equipment and its intended use.

Safety Precautions

This Manual uses the following words and/or symbols to indicate various ALERT levels.

DANGER means that you are very likely to be killed or injured if you don't take the needed steps to avoid the hazard. This is the highest level of warning.

WARNING is for a situation where you could be killed or injured if you don't avoid the hazard.

CAUTION means you could receive moderate or minor injuries, or equipment could be damaged if you don't avoid the hazard.

The Control Panel and/or other system components may the following Warning Labels affixed.

WARNING

Material Handling and Processing machines could cause **DEATH, SHOCK, or INJURY.**

LOCK OUT and **TAG OUT** machine **POWER** before installing loader.

Follow safety steps in machine manual during installation process or whenever adjusting loader.

WARNING

COMPRESSED AIR could cause **DEATH, BLINDNESS** or **INJURY.**

Avoid contact. Compressed air can enter through skin pores, causing injury or death.

Do not direct compressed-air jet stream at any person.

Wear safety eyewear wherever a Compressed-air source is in use.



UN-PACKING

The Whisper® Loader System is packaged in either a single carton or two cartons depending on physical size and/or carrier limitations.

CAUTION The carton contents will be encapsulated with foam-filled poly bags, usually in clam-shell fashion. Do not damage or discard packing materials. Check carton contents ensuring that each and every component has been carefully removed. Some models have the Control Panel attached directly to the Loader's Mounting Flange, while most others will have a Remote Panel. For added protection, the Panel will be packaged in a "Jiffy" padded envelope. If separate, the Control Panel will be resting on top of the Loader.

There will be a length of Flex Hose coiled at bottom of carton along with Hose Clamps. Placed vertically in a corner will be a Pick-Up Lance, two Lances on certain models.

Do Not set Loader on its' Dump Valve/Flap as damage may result.

It is recommended that all packing materials be retained for at least the duration of the warranty period, typically one year, in case the unit should need service or repairs beyond the user's capacity or expertise. See RMA section at the back of this manual for details on obtaining a Return Authorization Number.

If, when you unpack the Whisper® Loader equipment damage is observed, notify the carrier immediately to file a damage claim. Most carrier claim policies allow a fifteen-day window for such claims; therefore time is of the essence.



SYSTEM DESCRIPTION

IMS *Whisper*® *Loaders* packages are complete self-contained material-loading systems with an integral motor/fan (vacuum pump) providing efficient and economical operation with minimal maintenance and downtime. *Whisper*® *Loaders* are shipped ready-to-run with minimal set-up. They are pre-wired to plug into a grounded 120VAC/Ø1/20Amp receptacle (240VAC/Ø1/60Hz optional) and designed to automatically convey material from a local source (typically located within 10 feet) up-and-over to a machine material hopper, extruder, 'Day' bin or similar type of receiving vessel.

Standard packages include: Vacuum-Loader, Aluminum Pick-up Lance (sized to match line size of the Loader's inlet), 10-ft length of clear PVC Flexible Hose (sized to match) with a pair of Hose Clamps and Control Panel. The *Whisper*® *Loaders* is designed to automatically and efficiently maintain material levels in a receiving device, drawing material from the source – at a timed rate – set at the Control Panel. As an option *Whisper*® *Loaders* can be supplied with a *Vibra-Pulse*™ filter-cleaning system to automatically clean the filter following each conveying cycle.

IMS *Whisper*® *Loaders* operate on a batch principle. The duration of the conveying (run-time) and dump cycle (dump-time) is determined by the controller settings. The Control Panel is equipped with a PLC-type Controller module with adjustable (programmable) timer functions to control all timer-related Loader functions. Under special circumstances or for conveying distances greater than 10 feet, adjustments to the factory settings may be necessary. Refer to the PLC sections for further details.

The *Whisper*® *Loader's* conveying-cycle frequency is "on demand" and will continue to cycle (convey material) whenever the level in the receiving vessel falls below the point of the Loader's Dump Valve Flap, thus allowing it to close. Once the Dump Valve swings open the Proximity Switch no longer senses the presence of the Valve's Arm and in-turn signals the controller to stop the Convey Cycle.

Numerous *Whisper*® *Loaders* options are available beyond the Standard base model; from Filtration media (defined by the material being conveyed), receiving capacities, Proportional Conveying (from two material sources), Loader-construction (food-grade or other requirements). Standard *Whisper*® *Loaders* have a PLC Control Panel which can be configured for various types of functions including auxiliary equipment controls.

Please Note: As of August 2006, due to ever-changing technologies and depleted resources, the PCB (board) controller has been phased-out of current production. Customers who wish to retro-fit existing 070 Control Panels to a new PLC controller – may contact IMS Customer Service Department or a local representative for details.

COMPONENT, MODEL & OPTION DESCRIPTIONS

FEATURES and BENEFITS

- Stand-alone Self-contained design Vacuum-Conveying System
- Energy Efficient Solid State Controls operating on a Batch Principle
- Consistent loading of Machines, Hoppers or Day-Bins
- Spun & Welded Aluminum Body Construction – Standard
- Automatic Conveying for a wide range of materials and conditions
- Take-apart design for Easy Cleaning & Maintenance

BASIC COMPONENTS

The complete *Whisper® Loaders* Conveying System comprises the following major items (See Figure 1-1):

- Receiving Hopper Body with Inlet, Mounting Flange and Dump Valve Flapper Assembly with Proximity Switch (material level sensor)
- Flat-disc Nylon or Polyester-Felt media Membrane Filter (Vibra-Pulse™ filter-cleaning system optional) and Gasket to seal Cover to Body
- Integrated Motor/Turbine, Brush-type standard (Brushless type option available)
- Control Panel housed in NEMA 1 Enclosure with ON/OFF Switch, Indicator Lights, Control Cord and Power Cord
- Material Pick-up Lance and PVC Flex Hose (quantity doubled for PLVP models)

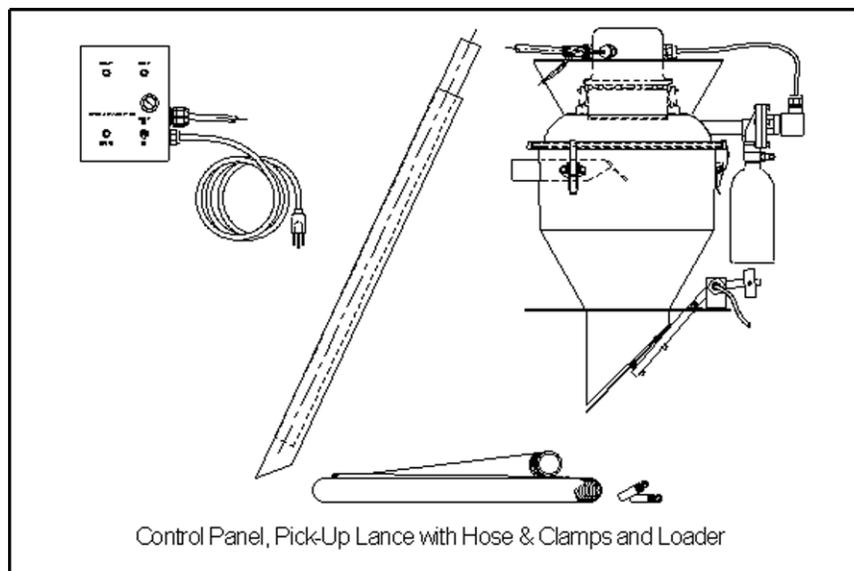

Figure 1-1 Major Components
(WL1500VP Whisper® Loader shown)



RECEIVING HOPPER

Constructed of spun-aluminum the Receiving Hopper Body includes a Discharge chute with Dump Valve and Mounting Flange. For material introduction an inlet (from Ø1-¼" thru Ø2" OD Tube Stub) is located on the side of the Loader's body. Proportioning (**PLVP**) models have two inlets (located side-by-side) permitting conveying multiple material types. As an option your Loader can be fitted with an Interblend® Static-blender as well as an optional Proximity Switch providing level-fill control at the **Virgin/Product 1** Inlet.

Whisper® Loaders with Powder (**PL**) model designation require taller bodies to allow for Filter Cartridge(s) from 6" to 12" tall as standard (18" or 24" tall optional) and additional Body height as required to allow for required material-receiving capacity below extent of filter cartridge. **PL1250** models have a single filter, while the **PL1500** models are supplied with three cartridges, see following **PL** section for further details.

TANGENTIAL-ENTRY (TE) INLET OPTIONS

The Tangential Entry series includes: Full (**FT**), Semi (**TE**), and Boxed (**BT**) Tangential Entries. The **FT** is a Full (flush to outside of Loader body) tangential-entry Inlet; the **TE** is a Semi tangential-entry Inlet is offset approximately ¾-distance from the center to the outside of the body; the **BT** is a round stubbed Inlet with a Full tangential-entry rectangular-design (boxed) transitioning connecting to the Body. Each Tangential Entry provides a degree of added protection for conveying delicate and fragile materials.

WEAR-RESIST (WR) INLET OPTION

The Wear-Resistant (**WR**) Inlet is designed to protect the conveyed product from damaging the Loader's inlet or the conveyed material itself as it is introduced into the Loader. The terminal end of the Inlet is capped providing an area where product is retained within the Inlet to cushion incoming material, an opening along the bottom of the inlet tube allows material to fall into the Loader's receiver body. Also a special Replaceable version, sleeved and/or flange-mount design, can be incorporated into the **WR** Inlet.

VIBRA-PULSE™ (VP) OPTION

The *Vibra-Pulse™* (**VP**) option to the Basic *Whisper® Loaders* is where the Loader's Cover Assembly is fitted with an automatic filter cleaning system:

Hardware: The **VP** System includes Loader Lid Assembly with integral Air Blast Pipes, Diaphragm Valve & Control Solenoid with Signal Cord, Air-Pulse Bottle and Air-supply Tubing (except 1250 models which have Pulse Valve and do not include Diaphragm Valve and Pulse Bottle assembly).

Function: At the end of each conveying cycle, the **VP** System will automatically clean the Filter(s) with a precision pulse of compressed air effectively loosening small particles and debris from the Filter's media.

PROPORTIONING-LOADER (PLVP) OPTION

The Proportioning-Loader **PLVP** *Whisper® Loaders* is designed to automatically and efficiently convey material from two individual sources. **PLVP** Loaders are available with the *Vibra-Pulse™* (**VP**) system. The **Virgin/Product 1** source conveying line is connected to the Left-hand Inlet, **Regrind/Product 2** source connects to the Right-hand Inlet.

Hardware: **PLVP** *Whisper® Loaders* are supplied with **VP** system (as shown above) two Pick-up Lances, a total of 20-ft of Flex Hose and (4) Hose Clamps (to accommodate both hose pieces). As an option the **PLVP** can be fitted with Interblend® (**IB**) Static-blender where the Loader's Receiver Body is divided into two compartments providing a rough mix of the ingredients prior to being discharged. The **IB** also reduces product layering within Loader.



Function: While the Loader is in the RUN mode, the Control signals **Ingredient 1** Valve to open drawing material from the **Virgin/Product 1** source for the allotted amount of time. At the elapse of T1 timer **Virgin/Product 1** Inlet Valve closes and **Regrind/Product 2** Inlet Valve opens to draw from **Regrind/Product 2** material source for duration of T2 timer. Total RUN time is culmination of both T1 & T2 timer functions. Simple Control Panel adjustments allow fine-tuning each timer.

POWDER (PL) OPTION

Powder (PL) model series *Whisper® Loaders* are designed to convey powders or other materials which produce a dusty bi-product. All PL Loaders are equipped with the **VP** System for automated filter cleaning. Series PL1250 models are a single-cartridge design with a Ø8" ID X 16" side-wall Body with the material Inlet located just below Filter and supplied with (1) Filter mounted onto the Ø9" 1C Tubesheet. Loader models PL1500 (Ø13" ID x 1" side-wall Bodies with Inlet on cone section) are three-cartridge designs supplied with (3) Filters mounted onto Ø14" 3C Tubesheet. Additionally special body design options allow for more capacity and/or taller filters as well as a selection construction materials and finishes to suit various requirements.

MOTOR/TURBINE

DANGER Please note that *Whisper® Loaders* are powered by electric motors and must be installed and operated in an environment where contact with foam, liquid (including water) or other foreign substances does not occur. Do not allow these types of substances to enter the fan system, motor housing or other electrical components. When operating *Whisper® Loaders* in potentially hazardous areas – environments containing dry chemicals or other volatile materials – an explosion-proof motor with special exhaust fittings must be utilized.

Failure to adhere to this precaution could lead to electrical shock resulting in flash fire (volatile substance exposure), equipment or property damage or personal injury or death. Review your application and/or installation with IMS prior to implementation.

The Vacuum Motor/Turbine assembly is a conventional 120VAC/60Hz/Ø1 Brush-type Motor coupled with a 2-Stage Turbine Fan. The Motor's Turbine produces two types of air movement: 1) Vacuum-conveying air which, after entering the Loader Body, is drawn up through the membrane Filter; and 2) Cooling/Discharge air. The Motor's cooling air is drawn through the openings in the top of the motor cover and discharged at the bottom periphery of the motor cover. Do not block air flow in and around the motor as damage may result. Typical life expectancy of the motor's brushes is approximately 400 operating hours. A SERVICE warning on the PLC appears when 400-operating hours has elapsed requiring Motor-Brushes to be changed; refer to the Maintenance section for details on replacing Brushes.

WARNING Failure to replace motor brushes in a timely manner may lead to irreparable motor damage, requiring motor replacement.

For special environment concerns *Whisper® Loaders* can be fitted an Explosion-proof Motor to work with flammable/explosive materials. In rare cases it may be necessary to utilize an inert-gas (Nitrogen) purge system to which IMS can provide a special motor with **N2** exhaust and recovery; also an optional closed-loop recover system is available. To meet these special circumstances IMS offers the following motor options:

240-Volt Motor

Whisper® Loaders equipped with 240-Volt (**240**) Motors are designed for operation with 240VAC electrical mains supply source. **WARNING!** If the *Whisper® Loaders* you purchased is equipped with 240VAC Motor and Controls **DO NOT** PLUG Control Panel cord into a power source other than 240VAC/60Hz/Ø1 or compatible voltage (i.e. 220VAC/50Hz/Ø1).



Explosion-Proof Motor (XP) Option

The Explosion-Proof Motor (**XP**) option to the *Whisper® Loaders* is required when hazardous conditions are present thus reducing the chance of accidental flash fires related to volatile materials or environment. The Loader is available with other options including NEMA 7/9 Control Solenoids.

Whisper® Loaders equipped with Explosion-Proof (**XP**) Motors are designed for operation in hazardous environments; therefore it is imperative that all electrical connections are made utilizing suitably rated components for such. Proper grounding reduces/eliminates ignition sources caused by build up of static electricity that could discharge possibly igniting explosive or flammable vapors or volatile materials. Loader function & operation is the same as with Standard Motor-powered *Whisper® Loaders*.

Brushless Motor (BL2) Option

The *Brushless (BL2)* is our 2nd Generation Motor with integral 2-Stage Fan system controlled by Switched-reluctance technology. The **BL2** model option has no **SERVICE** warning requirement. The major advantage of the **BL2** is there are NO brushes on the commutator to wear out, eliminating the need to maintain motor brushes, resulting in fewer maintenance checks. Typical motor life is approximately 4000 hr minimum. As an option the motor can be configured with Variable-Speed (**VS**) Control circuitry to accommodate conveying delicate materials at slower speeds or dense, robust materials at the normal higher speed. The **BL2** is designed for use on Loaders having inlets Ø1-½" or greater.

Note: Because the **BL2** motor design requires a unique Loader-Cover with mounting tabs a direct retro-fit cannot be incorporated onto an existing Brush-type Motor Cover Assembly.

PROXIMITY SWITCH

The frequency of material brought into the *Whisper® Loader* is primarily controlled by the material level in the receiving hopper; when the vacuum is off the Dump Valve Flap is allowed to open. The Proximity Switch senses the Flapper's Pivot arm unless the Flap is held open by material in the receiving receiver. The convey cycle is on hold until the material level in the receiving receiver drops down low enough to permit the Dump Valve Flap to close restarting the cycle.

FILTRATION

Proper filtration is crucial to the performance of your *Whisper® Loader* and provides protection to the Motor/Turbine assembly. Filters are installed between the *Whisper® Loader's* removable Lid Assembly and the Body's upper flange. *Whisper® Loaders* will have either of the following filter types installed: DI-AC (Diaphragm-Action), Poly-felt or Cartridge Filter (12" tall is standard, other cartridge lengths & filter media optional depending upon application). For most Pellet Loader applications the DI-AC filter is used. DI-AC Filters (Nylon media) are used for various applications (Standard models) and Polyester/Felt (PLVP & VP models) for dusty-material applications; while Cartridge-type Filters are used for powder-based materials.

Polyester/Felt Flat-Filter

The **Poly-Felt** Filters are 16 oz Woven Light-Grey Polyester-Felt blend media Calendered (Heat-set) one side with particulate filtration of up to 0.05 micron. The **Poly-Felt** Filter is engineered for use in dusty applications where the conveyed material is dusty or expels a dust like bi-product. Maximum operating temperature 375° F. Note: Although the **Poly-Felt** filter captures much smaller particulate matter it does exhibit airflow characteristics slightly lower than a **DI-AC** filter.



DI-AC Media Flat-Filter

IMS' **DI-AC** Filters are 1.12 oz Woven White Nylon monofilament providing excellent air-flow and filtration for particles as small as 55 micron.

Pleated Cartridge Filter

IMS Pleated Filters are Ø5-½" x 6" or 12" long (Standard lengths) Closed-end Cartridges with a Spun-bond 225 Thread-count Non-woven White Polyester Pleated media exhibiting excellent air-flow and filtration for particles as small as 2-microns. Cartridges provide either 5.5-ft² (6" tall) or 11-ft² (12" tall) filter area. Each Cartridge has a Galvanized Steel Closed-End Bottom Cap & Open-ended Top Cap with two Mounting Studs and is supplied with a Mounting Gasket.

Options to our Standard Cartridges include, but are not limited to: PTFE-coated media, High-temperature rated media, Food-grade media and Stainless-steel End Caps as well as various Cartridge lengths to suit special cloth-to-air ratio applications providing up to 22-ft² filter area.

The Filter may be adequately cleaned with a vacuum cleaner, blast of air, or (in extreme cases) washed with a mild detergent and warm water. Please refer to the Filter Maintenance section of this Manual for further details.

**DO NOT SUBSTITUTE FILTER MEDIA WITHOUT DISCUSSING YOUR APPLICATION
WITH A IMS APPLICATION ENGINEER OR CUSTOMER-SERVICE REPRESENTATIVE**

GASKETS

Filters & Tubesheets

PLVP, VP and **Standard** models utilize Flat disc-type Filters. Proper Membrane-type Filter installation incorporates a Gasket (e-shaped cross-section) placed around the periphery of Filter to make an air-tight seal between the Loader Body & Cover Assembly.

When re-installing Flat-Disc type Filters ensure the Filter's periphery is first installed in the slot of the Gasket with Filter seam-side facing up/smooth-side down (away from the motor). The Gasket orientation will be flat-side facing up/curved-side down (see diagram).

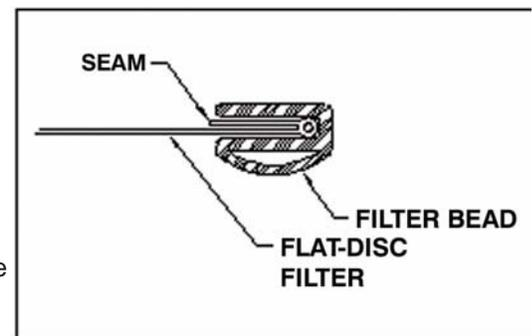

PL model loaders have cylindrical Pleated Filter Cartridge(s) installed. Each Cartridge is first mounted onto the Tubesheet using the Filter-mount Gasket provided. The Tubesheet will a Body-to-Lid Gasket (e-shaped cross-section) installed on the perimeter of the Tubesheet prior placing Filter/Tubesheet Assembly into the Loader's Body. The Loader's Lid can now be set in place and secured with the draw-type Latches.

When re-installing Cartridge-type Filters, mounted on a Tubesheet, the Tubesheet Gasket is installed with the flat-side facing up (towards the Motor – away from Loader Body).

Motor

Motor-mount Gasket is affixed to the top surface of the Lid. The Motor is then installed atop Gasket to seal. The Gasket ensures proper channeling of the Vacuum-conveying air up through Cover & Motor Assemblies.

CONTROLLER

CONTROL PANEL

The Control Panel's Enclosure (Fig. 2-1) includes a combination ON/OFF/Circuit-Breaker Switch, Status-Indicator Lights, Control Cord and Power Cord. Depending upon your particular Loader's functions, the Panel may have a different arrangement of Door-mounted controls and indicator lights than shown.

Control Panels on WL1250 & WL1250VP Whisper® Loaders are mounted directly to the Loader's mounting flange. Control Panels on WL1250PLVP, PL1250 & all other models are remotely-connected to the loader by the Control Cord. See Model-specific drawings (provided with this manual) for applicable wiring diagrams.

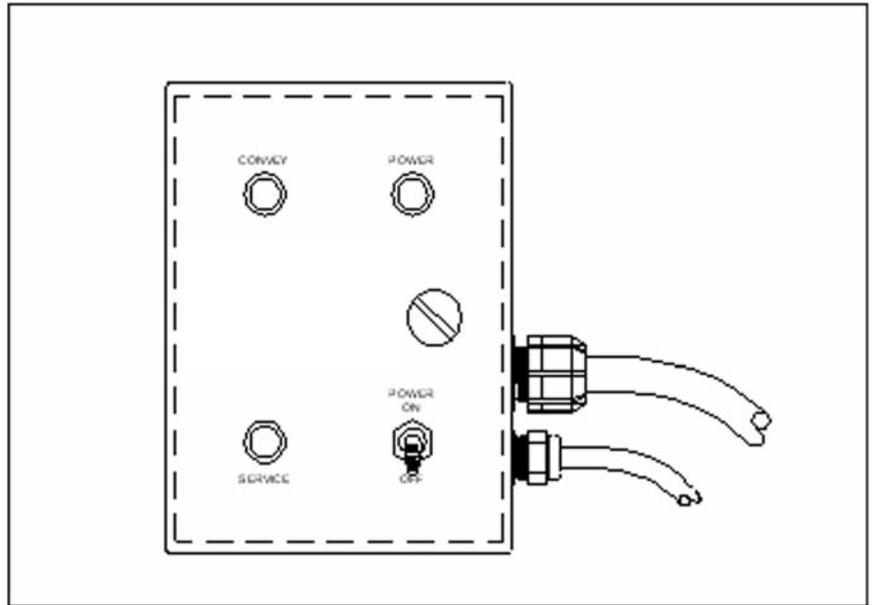

Figure 2-1 Control Panel Enclosure

The Control Panel is housed in a NEMA 1-rated enclosure with hinged access door and configured for 120VAC/Ø1/60Hz standard, 240VAC/Ø1 and other electrical power options are available. Use caution when plugging unit into receptacle – know your set-up beforehand.

PLC CONTROLLER

Factory Settings

Settings may be adjusted in the field to suit material conveying and/or operating conditions not covered in this manual. Consult factory to review special circumstances prior to making any changes.

Quick-Start

Keypad Terminal: Initial Screen at Power-On will display System, Stop/Run or other Loader-function status. See Figure 2-2 for PLC Module's Keypad layout.

Pressing "Ok" brings up the Menu Selection Screen. Press the Center Pad "DOWN" Arrow until "Parameter" function is flashing. Press "Ok" to access the Timer-functions Screen.

Press UP or DOWN Arrow until desired Timer is selected then press "Ok" for next screen. From here set time desired by pressing "Ok" while first-digit is flashing. Press Right Arrow (Center Pad) until the next digit to be changed flashes, and then UP or DOWN arrow until desired value is displayed. Repeat until entire time value is entered. Press "Ok" to save and then "Esc" to return to the previous menu. Press UP or DOWN arrow to access another Timer or "Esc" to save and return to previous menu.

Press "Esc" once again to return to the RUN Screen.

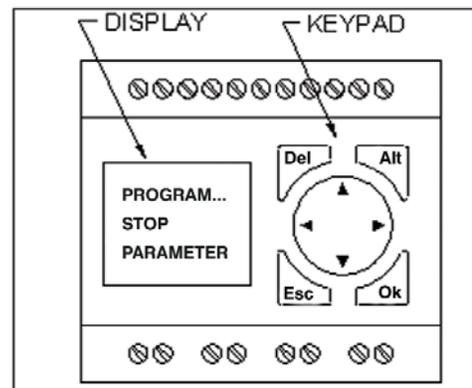

Figure 2-2 Module Keypad Layout

Timer Descriptions & Functionality

PL, VP & Standard (Basic) Whisper® Loader Models:

- T1: Run Time (Filling Duration)
- T2: (Not used)
- T3: Dump Time (Discharge Duration)
- T4: Pulse-Off Time (Duration between Pulses) for PL & VP (not used on Standard model)

PLVP Whisper® Loader Models:

- T1: Proportioning Time (Filling Duration), Virgin/Product 1 Material
- T2: Proportioning Time (Filling Duration), Regrind/Product 2 Material
- T3: Dump Time (Discharge Duration)
- T4: Pulse-Off Time (Duration between Pulses)

Optional Set-up:

On-Line/Off-Line Pulse Jumper Settings for the PLC Control Module to control the *Whisper® Loader's Vibra-Pulse™* Filter-Cleaning System. **PLVP & VP Model Whisper® Loaders** are set for On-Line Pulse and **PL models** are set for Off-Line Pulse. For factory default jumper settings see Figure 2-3 diagrams below.

Caution: Refer to Wiring Diagram provided in your *Whisper® Loader* Operating Manual as the applicable Input Contacts may vary from that shown below. The Wiring Diagram supplied with the Loader will identify the actual jumper location & related input terminal & wire numbers.

On-Line Pulsing occurs while the system is in the Conveying or Run Cycle (pulses the filters during the Conveying cycle), Off-Line Pulsing occurs while the system is in the Dump Cycle (pulses filters during the Dump cycle).

DANGER! Prior to performing ANY service or repairs **LOCK OUT** and **TAG OUT** electrical power & de-energize compressed-air sources.

To set On-Line Pulsing: Add **Jumper** wire from Wire #4 Terminal (L1 on the PLC Controller) to Wire #11 Terminal (I-4 on the PLC Controller).

To set Off-Line Pulsing: Add **Jumper** wire from Wire #4 Terminal (L1 on the PLC Controller) to Wire #9 Terminal (I-3 on the PLC Controller).

Note: There are no physical jumper wires at either I-3 or I-4 terminals other than the **Jumper** wire; wires depicted are for illustration purposes only.

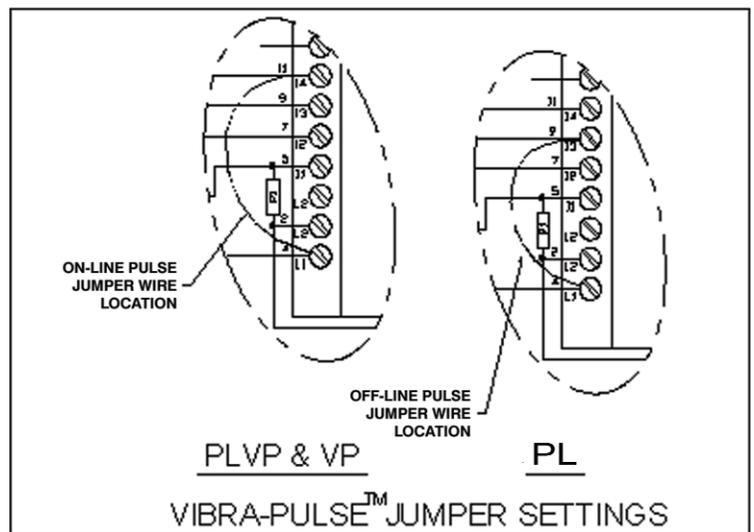

Figure 2-3 Jumper Settings



CIRCUIT-BREAKER

To protect circuitry, the Control Panel ON/OFF Switch incorporates a Circuit Breaker providing overload protection. Should an overload condition arise the breaker trips putting the Switch's Baton in neutral. To reset breaker merely flip the switch to OFF, and then back to the ON position.

SERVICE MESSAGE

This section refers to *Whisper® Loaders* with Brush-type Motor. IMS recommends replacing the motor brushes after 400 hours of operation to prevent detrimental damage to the Motor. The Control Panel's internal timer device records accumulated hours of operation; at the 400 hours screen will display service message – the Brushes must be changed. Once replaced the **SERVICE** Alarm must be reset by depressing the **UP** button on the PLC Keypad (see Figure 2-1 or 2-2).

Note: Failure to replace brushes in a timely manner will eventually damage the commutator requiring complete Motor/Turbine replacement. Please refer to Maintenance section for details on changing Brushes and other motor-related maintenance issues.

Material Pick-Up

As standard a material Pick-Up Lance with Flex Hose are included with each *Whisper® Loader* system. On Loaders with the **PLVP** option, two Pick-Up Lances plus an additional 10-ft length of Flex Hose (20-ft total) & two additional Clamps (4 total) are supplied to accommodate both material Inlets.

PICK-UP LANCE

The Pick-up Lance is the material pick-up device which draws air down the crescent-shaped opening between the Outer Tube & Inner Probe (this area must remain open to air, DO NOT block or allow top-end to be inserted below material level) and then into source bin. There it will capture material and convey it up through the Lance's Inner Probe (inner probe sized to match line size of the loader inlet); then through the Flex Hose with final destination at the Loader Inlet. Pick-Up Lance options include; material of construction, adjustable take-apart sanitary designs, and Bag Guard protective End-pieces.

HOSE

10-foot long PVC Flex Hose (inner diameter sized matches Loader's Inlet) with Integral Copper Ground Wire (to reduce/eliminate static built up). A pair of Stainless steel Worm-drive Hose Clamps is provided as standard. One end of the Flex Hose is attached to the Pick-up Lance's Inner Probe, the other end attached to the Loader's Inlet.



Installation

Instructions for installing and setting up an IMS *Whisper® Loader Vacuum-Conveying System*: *Whisper® Loaders* should not be connected to extension cords as this may cause the circuit-breaker to trip due to voltage drop. Desired mounting surface (i.e. extruder, molding machine feed-screw inlet, hopper or day-bin) must be horizontal, flat (warp-free) and free from debris. Ensure surface is mechanically sound and able to rigidly support the *Whisper® Loader*; bolt in place at the Mounting Flange. For your convenience a Flange mounting-template drawing is included. IMS offers an array of Hopper Covers to provide a custom fit on your material hoppers and other containers.

The receiving hopper should be vented to prevent pressurization. When properly mounted the Discharge Flapper (Dump Valve) **MUST** be slightly open with an approximate gap of 1/4" at the lower-most point (when system is not in vacuum mode). The counterweight on the Dump Valve pivot arm is factory adjusted and should require no further adjustment. Care should be taken to ensure the Dump Valve mechanism is working properly and able to swing freely to a full-open (flap vertical) position. Remedy any mechanical interference prior to placing *Whisper® Loader* into service. For Proximity Switch sensitivity adjustments and/or mounting instructions refer to applicable attachment(s) included with this manual.

On *Whisper® Loaders* (PLVP, PL & VP Models) with *Vibra-Pulse™ (VP)* option it is necessary to connect a dedicated, filtered, compressed-air supply line (see table for sizes) to the air INLET fitting on the **VP** Solenoid.

Loader Model	Line Size	Pressure Required
WL1250PLVP & VP Models (without Pulse Bottles)	3/8"	60-80psi
All other PLVP/PLZ & VP Model series (with Pulse Bottles)	1/4"	40-60psi

Next, make the material-conveying line connections by attaching one end of the provided Flex Hose to the Loader's Material Inlet and the other end to the Pick-up Lance's inner probe; secure using Hose Clamps provided. To reduce or eliminate static build-up within the conveying line and/or conveyed material attach the Flex Hose's integral Ground Wire to the Probe & Loader. Expose a short length of the wire at each hose-end, tuck inside of hose prior to connection. Routing of the Flex Hose should be as direct and straight as possible. Avoid tight-radius bends or kinking Flex Hose as this will impede flow resulting in sluggish system performance.

Now place the Pick-Up Lance into material source. Do not allow material level to be higher than the upper end of the Outer Tube as material will enter causing poor flow – even blockage.

For installations where the conveying distance is greater than 10 feet, longer hose lengths or rigid metallic tubing may be required. IMS recommends Aluminum tubing for its light-weight characteristics, ease of handling and inherent corrosion-resistant qualities. For conveying of abrasive materials carbon steel or stainless steel bends may be incorporated into the conveying line run.

Metallic tube bends/sweeps should have a centerline radius (twelve time tube outside diameter) on the material-conveying line. Material-conveying lines to be configured having predominately horizontal or vertical straight runs with a minimum number of bends to prevent "plugging" of the material. Please contact our Parts Department for assistance in selecting proper Bends, Sweeps and Couplings. Certain materials being conveyed may require conveying lines of either carbon steel for its ruggedness, or stainless steel to meet food-grade and/or clean room requirements. Compression-type Couplings with 3-Bolt or 4-Bolt Clamps are best suited for metallic-tube connections, please refer to Compression-Coupling section for additional information. Periodic inspection of the conveying line hose & tube, its condition and routing should be incorporated into the system's regular maintenance program.



Sequence of Operation

The following is the sequence of operation for Self-contained Vacuum *Whisper® Loaders*:

1. When the Control Panel Power Switch is in the **ON** position, the **POWER** light is on. If the Receiving Hopper is empty, the Dump Valve is allowed to close initiating signal to convey material, turning on the motor/turbine for the programmed amount of time (T1). While the motor is running, the **CONVEY** light is **ON**.

1.1 **PLVP** *Whisper® Loaders* have two ratio-controlled (proportioning) Material Inlets to draw from either of two sources: Virgin/Product 1 or Regrind/Product 2 material. Virgin/Product 1 proportioning valve will open to allow material to be conveyed (the Control Panel's Virgin/Product 1 indicator will be illuminated). After conveying the Virgin/Product 1 for prescribed time (T1), the Valve will close and then the Regrind/Product 2 Inlet valve will open allowing its' material to be conveyed (the Regrind/Product 2 indicator light is illuminated during this time). Once the total conveying time (T2) is achieved, the Loader will idle as described in Step 2.

2. The Loader will idle for the programmed **OFF** time (T3 - Off delay), allowing all material in the Loader to discharge into the receiving hopper.

3. For **VP** Loaders (**VP**, **PL** & **PLVP** models) the Motor idles in the **OFF** time mode, the Loader Control will automatically energize the **VP** Solenoid opening (T4 – Duration between Pulses) the Valve producing micro-blasts of air directed at the Filter(s) knocking particles safely away.

4. If the Dump Valve is held open by material in the receiving hopper, the Loader will continue idling until material falls low enough to allow the Dump Valve to close. The Proximity Switch senses the return of the pivot arm which in-turn signals the Control Panel.

5. After the signal, the Loader's RUN-Time starts producing vacuum and restarts sequence steps 1 thru 4. The Loader will cycle **ON** and **OFF** automatically to maintain level in the receiving hopper.

NOTE: Material density, moisture content and its flow characteristics (as well as other environmental factors) play a part in the system's overall conveying efficiency. Therefore, it may be necessary to make further adjustments outside of those mentioned in this manual. Make notations of these adjustments on the note page (contained herein) or in your maintenance records in case you need to reset factory settings. Incorporate these findings into a regularly scheduled maintenance/check routine.



Maintenance

DANGER! Prior to performing any service or repairs **LOCK OUT** and **TAG OUT** electrical power and de-energize compressed-air sources.

MOTOR

Brush-type Vacuum Motors generally last a long time when properly maintained. Check Brushes regularly, replace at the accumulated operating time of 400 hours – the Control Panel indicator reminds the user of this important milestone. Replace worn or damaged Brushes immediately.

The optional Switched-Reluctance Brushless-type Motor of course does not need Brush service. Proper break-in of new brushes required prior to applying full-load electrical current.

Motor Replacement

1. **Disconnect Power Cord from receptacle.**
2. Remove electrical quick-disconnect Cords (Proximity Switch and Control) from the Motor Cover. These are threaded-body QD connectors. Rotate knurled Ring counter-clockwise to disconnect then unplug cord from receptacle.
3. Depress lock button to disengage each Latch holding the Motor-Cover onto the Motor.
4. Lift off Motor Cover to gain access to the Motor.

CAUTION! Exercise CAUTION performing steps 4a thru 4c. Rotate Motor Cover while lifting, avoid pulling on or otherwise damaging lead-wires, as they are permanently attached to the motor and are somewhat delicate. If these wires do get damaged beyond SAFE use, the entire motor needs to be replaced.

- a. Disconnect the wire-nuts connecting the Motor lead-wires to Control-Cord Receptacle (Connector for the large yellow-jacketed Cord).
 - b. Disconnect Motor ground wire.
 - c. Remove Motor (lead-wires intact).
5. Install NEW Motor and reconnect all wires, reversing steps above. Check condition of Motor-mount Gasket attached to Loader Cover, if necessary replace.
 6. Replace the Motor Cover, making sure the lead-wires are not damaged.
 7. Secure both Motor-Cover Latches (ensuring that a “click” is heard) locking them in place.
 8. Reconnect the Proximity Switch and Control QD (yellow-jacketed) Cords.
 9. Plug Loader’s Power Cord into receptacle.
 10. Press the UP button on the PLC board to reset the SERVICE Alarm (Loader must be connected to power source and Power switch turned ON to reset).

Your *Whisper® Loader* is ready to be put back into service.

Motor Brush Replacement

1. **Disconnect Power Cord from receptacle.**
2. Remove electrical quick-disconnect Cords (Proximity Switch and Control) from the Motor Cover. These are threaded-body QD connectors. Rotate knurled Ring counter-clockwise to disconnect then unplug Cord from Receptacle.
3. Depress lock button to disengage each Latch holding the Motor-Cover onto the Motor.

CAUTION! Exercise CAUTION when performing step 4. Rotate Motor Cover while lifting, avoid pulling on or otherwise damaging lead-wires, as they are permanently attached to the motor and are somewhat delicate. If these wires do get damaged beyond SAFE use, the entire motor needs to be replaced.

4. Lift off Motor Cover and set aside – leaving lead-wires attached – to gain access to Motor.
5. Carefully spread snap-on “Ears” of the plastic Fan Cover and remove to expose Motor Brushes.
6. Remove Brush-retaining Screws.

7. Place small-blade standard screwdriver between outer plastic Brush Housing and wire Slide Clips. Carefully pry outward with screwdriver – just enough to push Slide Clips closer to the Brush and slide it out from its locked position.
8. Insert NEW Brushes. Both Brush mechanisms must be replaced as a set.
9. Return Slide Clips to their locked positions to secure Brushes. Replace Brush-retaining Screws and plastic snap-on Fan Cover.

WARNING! DIRECT APPLICATION OF FULL-RATED VOLTAGE TO UNSEATED BRUSHES WILL CAUSE ARCING & PITTING OF THE COMMUTATOR REDUCING MOTOR LIFE.

10. To achieve optimum performance from your motor, new brushes should be seated on the commutator BEFORE applying full-rated voltages. Following Brush-set change apply 50% to 75% of rated voltage for thirty minutes to seat faces of Brushes on commutator. The motor will run achieve full-potential performance following thirty to forty-five minutes of operating at the full-rated voltage. Do not block off vacuum air inlet when running the motor. Alternately, if reduced voltage is not available for this step, two motors of like rating in series for the allotted time will provide the same results as above.
 11. Follow any additional OEM instructions provided with the Brushes to obtain full brush life and peak motor performance.
 12. Replace the Motor Cover, making sure the lead-wires are not damaged.
 13. Secure both Motor-Cover Latches (ensuring that a “click” is heard) locking them in place.
 14. Reconnect the Proximity Switch and Control QD (yellow-jacketed) Cords.
 15. Plug Loader Power Cord into receptacle.
 16. Press the UP button on the PLC board to reset the SERVICE Alarm. Press the UP button on the PLC board to reset the SERVICE Alarm (Loader must be connected to power source and Power switch turned ON to reset).
- Your Whisper® Loader is ready to be put back into service.

FILTER MAINTENANCE

Filters are crucial to the Whisper® Loader’s performance AND provide protection to the Vacuum Motor/Fan Assembly. Check filters DAILY. Filters are cleanable, whether Flat-disc type or cylindrical Cartridge type. However, you exercise care and follow the procedures outlined below. Should filter(s) require more-frequent manual cleaning please review your specific operating conditions with PCI Customer Service to achieve a reduction-in-maintenance solution.

CAUTION DO NOT use excessively-high air or water pressure. DO NOT use stiff-bristle brushes or similar devices. DO NOT otherwise scratch specially-treated filter surfaces. DO NOT use oils, solvents, harsh detergents or other abrasive cleaning agents & solvents. DO NOT apply direct (perpendicular to the pleated surface) air or water pressure on the dust side of the filter. NEVER point compressed-air nozzles directly at anyone! DO wear appropriate protective clothing for the contaminant you are cleaning and ensure any residue generated is properly contained and discarded per local environmental regulations.

Flat Filters

CLEANING: DRY METHOD

Should DI-AC (Nylon) and Poly-Felt Flat Filters require cleaning, even beyond the capabilities of the Loader’s Vibra-Pulse™ system, remove and clean as follows:

1. Unlatch Lid, remove filter from Whisper® Loader.
2. While holding filter at the perimeter Ring lightly tap (smooth side) against a firm surface to dislodge majority of larger particles.
3. Thoroughly vacuum; first from smooth side then seam side, so as not to embed particles further into media.
4. Repeat from smooth side to seam side until all visible debris has been removed.

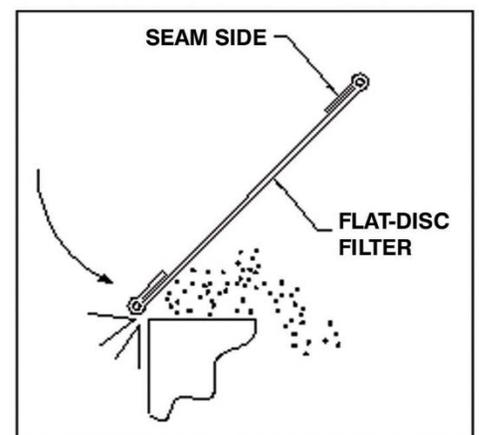

CLEANING: WET METHOD

Additionally DI-AC filters can be cleaned using a mild detergent and air-dried.

1. Place filter in a 2%-3% (approximately 4 oz per gallon of water) solution of mild dish soap such as Ivory®, Joy® or Palmolive®. Allow to soak for about ten minutes.
2. With seam side facing you, wash filter. DO NOT scrub excessively as damage may result.
3. Remove from solution and rinse thoroughly, from the seam side straight through, under low-pressure stream of water. Rinse smooth side, and again from seam side until all soap residual is removed.
4. Allow filter to air dry completely, normally 24-48 hour period @ 70° F or lower. DO NOT dry filter inside of the Loader. DO NOT apply direct heat as damage will result.

Cartridge Filters

PTFE-Coated Cartridge

WARNING! If your *Whisper® Loader* is fitted with special PTFE-coated Filter(s) use extreme caution during handling and cleaning of the cartridge(s). You are cleaning filter media surface-coated with a PTFE membrane (approximate thickness of 1 to 1-½ mills or about 1/8 the thickness of plumber's tape) laminated onto a non-woven, spun-bond substrate. DAILY Filter Inspection is required. Clean periodically as dictated by service load, replace when damaged or worn as surface abrasions and damage adversely affect filter performance. **DO NOT SCRUB.**

CLEANING: DRY METHOD

Vibra-Pulse™ pre-clean Cartridge(s) Off-line (Vacuum Motor off) for approximately ten minutes with the Loader's **VP** system frequency setting at 15-second intervals at 100-milliseconds. The **VP** Valve shall remain connected to 60psig compressed-air source.

Should Pleated Cartridge Filters require further cleaning beyond that accomplished by the Vibra-Pulse™ system, remove and clean as follows:

1. Carefully lift out Tubesheet/Cartridge assembly from *Whisper® Loader*.
2. Loosen the Cartridge mounting hardware and remove Filter(s) from Tubesheet.
3. The Tubesheet material-contact surface can be cleaned as required at this time. Dry thoroughly.
4. While holding filter at the Upper (open) End Cap lightly tap (Bottom End Cap) against a firm surface to dislodge majority of larger particles, rotating as you work completely around filter.
5. Lightly brush excess debris lodged within pleats in a sweeping motion as required starting from each end and working towards middle of filter. Turn filter over end-for-end and repeat.
6. And/or vacuum, from dust side, using a soft-bristle brush so as not to embed particles further into media.
7. Vacuum inside at closed End Cap to remove accumulated debris – if any.
8. Apply a jet from compressed-air nozzle/wand held away from surface at 45° to filter's surface. DO NOT allow air device to scrape filter surface as damage may result. The air device opening must Ø3/8" or larger to prevent filter damage. Move nozzle along the full length of filter in a steady up & down motion.
9. Using same technique in step 8, sweep inside of cartridge.
10. Repeat step 8 & 9 again to provide a clean sweep of both the inside & outer surfaces.
11. As an option, a vacuum nozzle can be used to clean the pleats as described in steps 8 & 9.

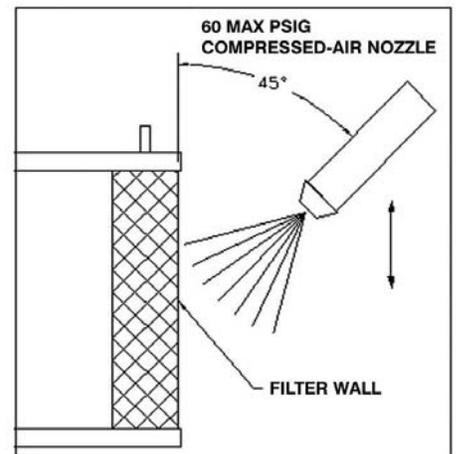
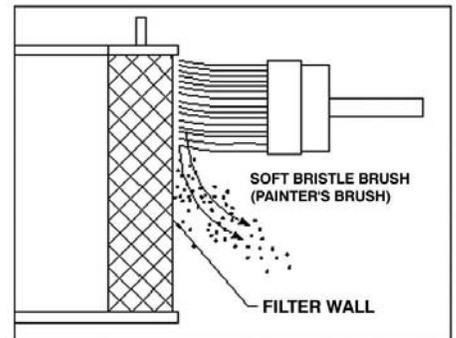

CLEANING: WET METHOD

Additionally Cartridge Filters can be cleaned using a mild detergent and air-dried.

1. Pre-clean and brush Cartridge as described in Dry-Method above to remove excess dust particles.
2. Place filter in a container with 2%-3% (approximately 4 oz per gallon of water) solution of mild dish soap such as Ivory®, Joy® or Palmolive®. Allow to soak for ten minutes.
3. Remove from solution and flush with stream of clean low-pressure water. Hold hose end/nozzle away from and at 45° to filter surface. Water stream must not exceed 70 psig. **DO NOT SCRUB.**
4. Rinse thoroughly, from the inside straight through to outside, under low-pressure stream of water. Rinse until all soap residual has been removed.
5. Allow filter to air dry completely, normally 24-48 hour period @ 70° F or lower. DO NOT dry filter inside of the Loader. DO NOT apply direct heat as damage will result.

WIRING DIAGRAMS

WIRING DIAGRAM FOR WL1250/1500

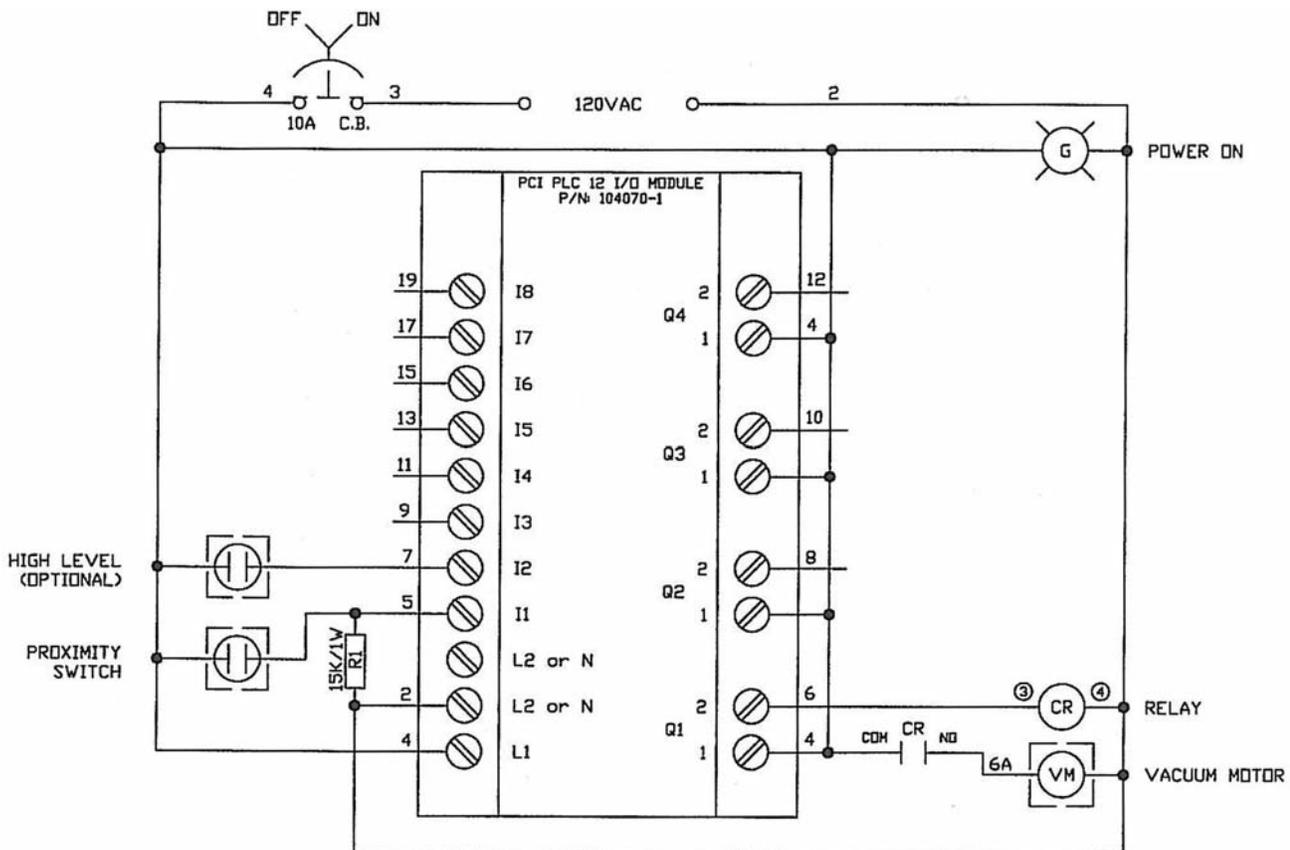

WIRING DIAGRAM FOR WL 1250/1500PLVP

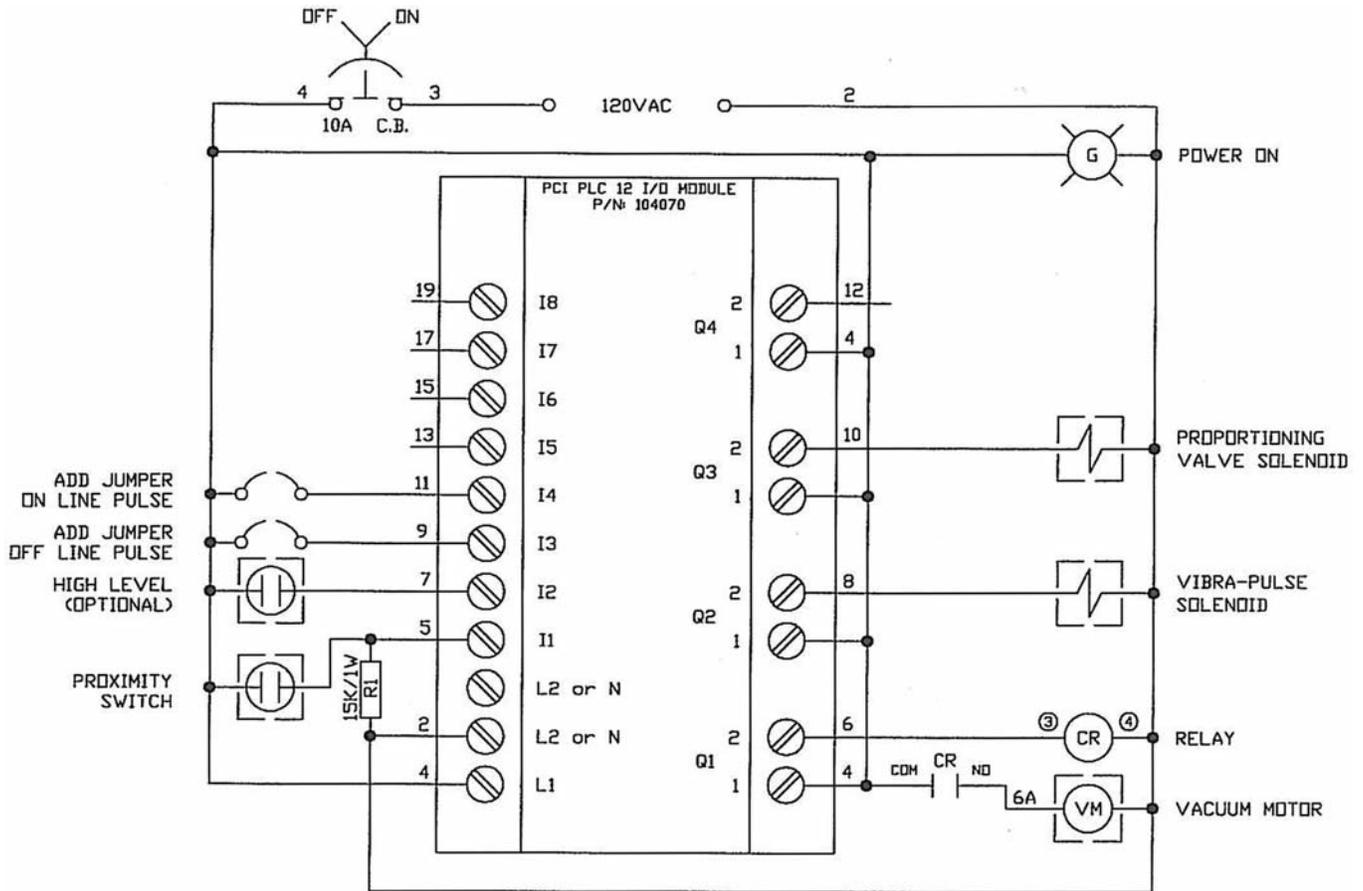

WIRING DIAGRAM FOR WL1250/1500 PR/VP

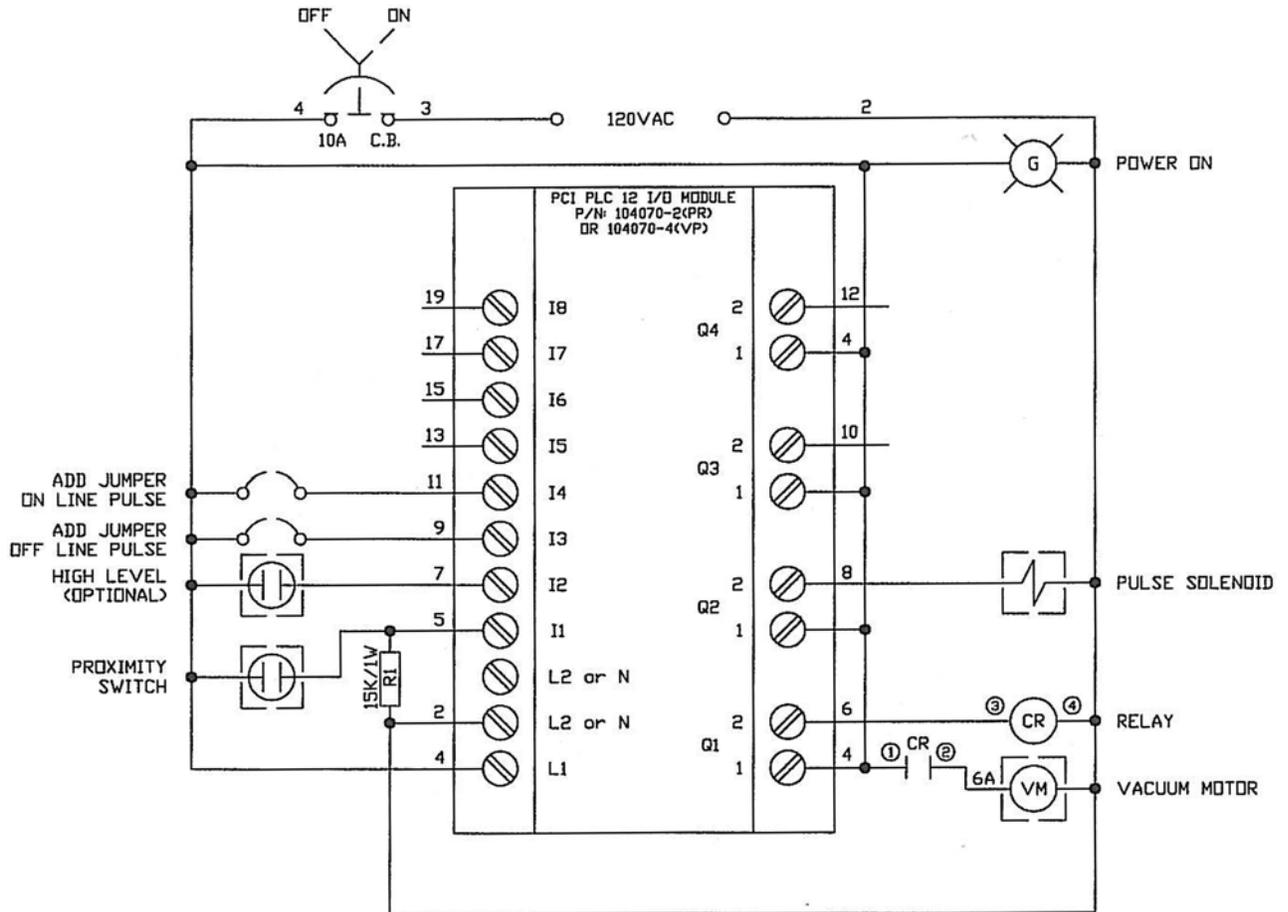



Troubleshooting

The following situations may occur when installing or operating the *Whisper® Loader*, please attempt to remedy the problem you have encountered prior to contacting IMS or its representatives for service. Exercise applicable safety precautions while working on electrical devices or compressed-air equipment.

DANGER! Prior to performing any service or repairs **LOCK OUT** and **TAG OUT** electrical power.

Problem	Probable Cause	Solution
Material is not being conveyed	<ol style="list-style-type: none"> 1. Filter blinded or plugged 2. Conveying Line clogged 3. Dump Valve not Sealing 	<ol style="list-style-type: none"> 1. Remove and Clean 2. Clear line 3. Check for bent Flapper or foreign-object obstruction
No Virgin Material being conveyed	<ol style="list-style-type: none"> 1. Virgin Line Valve remains closed 2. Control Knob is not turned to the full clockwise position 	<ol style="list-style-type: none"> 1. Check Valve's Air Cylinder and Solenoid 2. Turn Control Knob CCW
No Regrind Material being conveyed	<ol style="list-style-type: none"> 1. Regrind Line Valve remains closed 2. Control Knob is not turned to the full counter-clockwise position 	<ol style="list-style-type: none"> 1. Check Valve's Air Cylinder and Solenoid 2. Turn Control Knob CW
Motor has high-pitched runaway sound during conveying cycle	<ol style="list-style-type: none"> 1. Loader Receiving Hopper Body full 	<ol style="list-style-type: none"> 1. Shorten Motor ON time
Motor continues to cycle after receiving hopper is full	<ol style="list-style-type: none"> 1. Proximity Switch being activated 	<ol style="list-style-type: none"> 1. Check that Dump Valve Pivot Arm is NOT sensed by Proximity Switch, make necessary adjustments 2. Faulty Proximity Switch
Motor does not run	<ol style="list-style-type: none"> 1. No 120 Volt supply 2. Breaker tripped 3. Motor Brushes improperly installed or worn out 	<ol style="list-style-type: none"> 1. Remedy as required 2. Reset Breaker 3. Re-install Brushes, perform brush-seating procedure or replace Brushes
Power light does not operate	<ol style="list-style-type: none"> 1. No 120 volt supply available 2. Tripped circuit breaker 	<ol style="list-style-type: none"> 1. Check for power at outlet 2. Reset or check Breaker
Circuit-Breaker Switch fault	<ol style="list-style-type: none"> 1. Pinched or chaffed wires 2. Incorrectly-sized Breaker 	<ol style="list-style-type: none"> 1. Check under Motor Cover and inside Enclosure for pinched or damaged wires 2. Install correctly-sized Breaker
Filter (Flat Disc or Cartridge type) quickly becomes clogged or dirty	<ol style="list-style-type: none"> 1. No air supply available (keeping Vibra-Pulse™ from performing) 2. Air pressure too low (keeping Vibra-Pulse™ from working correctly) 3. Pulse cycle setting too low, not enough pulses during OFF time 	<ol style="list-style-type: none"> 1. Check for broken or loose airline fittings 2. Increase air supply pressure – Do Not exceed 100psi 3. Decrease cycle lengths for more pulses during OFF time



1250 Loader Series Mini Loader Replacement Parts

Item #	Description
105986	9" dia. nylon filter (for 1250A units)
106036	9" dia. polyester felt filter (for 1250VP and 1250PLVPA units)
120065	Powder loader filter (also for PL1500 units - 3 required)
106002	9" gasket for all 9" filters
117362	Gasket between motor and cover (for all 1250A and 1500A units)
106021	Vacuum motor with fan (for 1250A, 1250VP and 1250PLVPA units)
105987	Brush kit (change brushes every 300 hours)
149083	PLC Controller with standard program
149084	PLC Controller with VP program
149085	PLC controller with plvp program
118589	Switch, 10 amp circuit breaker
116286	Proximity switch (for all 1250 and 1500 units)
105969	Dump Valve Assembly (for 1250 units)
106056	Solenoid valve, 4-way (1250PLVPA and 1500PLVPA units)
106031	Motor housing connector, 5 pin (for 1250A and 1500A units)
114245	Motor housing connector, 6 pin (for 1250PL/VP and 1500 PV/VP units)
107656	Motor housing connector, 7 pin (for 1250 PLVPA and 1500 PLVPA units)
116050	Proximity cord (for all 1250 and 1500 units)
106023	1 $\frac{1}{4}$ " pick-up wand
108844	1 $\frac{1}{4}$ " I.D. loader hose
108207	1" to 2" worm gear clamp
120669	Lid with latches, including gasket (for 1250VP and 1250 PLVPA units)
123471	Lid with latches, including gasket (for 1250A units)
137590	Retro Fit Kit 1250 - 1500 (to convert an old loader with an 070 pbc board to the PLC controller)
137591	Retro Fit Kit VP – PL (to convert an old loader with an 070 pbc board to the PLC controller)
137592	Retro Fit Kit PLVP (to convert an old loader with an 070 pbc board to the PLC controller)

NOTE: In 2006, IMS upgraded its loaders from boards to modules. These modules are self-contained and when installed correctly will eliminate dust and static wire issues.



1500 Loader Series WHISPER® Loader Replacement Parts

Item #	Description
105977	14" dia. nylon filter (for 1500A units)
106026	14" dia. polyester felt filter (for 1500VP and 1500PLVPA units)
120065	Powder loader filter - 3 required (also for PL1250 units)
105990	14" gasket for all 14" filters
117362	Gasket between motor and cover (for all 1250A and 1500A units)
106008	60 psi filter regulator (for 1500A, 1500VP and 1500 PLVPA units)
106021	Vacuum motor with fan (for 1500A, 1500VP and 1500PLVPA units)
106053	Stationary fan to vacuum motor (for all 1250 and 1500 units)
106059	Rotating fan to vacuum motor (for all 1250 and 1500 units)
106407	Vent fan for vacuum motor (for all 1250 and 1500 units)
108830	Vent fan housing (for all 1250 and 1500 units)
106407	Vent Fan Blade, 2 7/16" dia, 1/4" Bore (for all 1250 and 1500 units)
106410	Armature to vacuum motor (for all 1250 and 1500 units)
105987	Brush kit (change brushes every 300 hours)
105970	Flapper only (for all 1500 units)
105978	Lid, latch and sound hood (for 1500VP and 1500PLVPA units)
106052	Check valve assembly (for 1500 PLVPA units)
119984	Proportional cylinder port plugs (for 1500PLVPA units)
149083	PLC Controller with standard program
149084	PLC Controller with VP program
149085	PLC controller with plvp program
119393	Pulse valve assembly (for 1500VP and 1500PLVPA units)
118589	Toggle switch, on/off (for all 1250 and 1500 units)
116286	Proximity switch (for all 1250 and 1500 units)
106056	Solenoid valve, 4-way (1250PLVPA and 1500PLVPA units)
106031	Motor housing connector, 5 pin (for 1500A units)
114245	Motor housing connector, 6 pin (for PL and VP units)
107656	Motor housing connector, 7 pin (for PLVPA units)
106014	Interconnect cord, 5 pin (for 1500A units)
106714	Interconnection Cord, Motor to Control Box, 7-Wire, 12ft. OAL (for 1500PLVP units)
109118	Interconnection Cord, Motor to Control Box, 6-Wire, 12ft. OAL
116050	Proximity cord (for 1250A and 1500A units)
105999	Control box, complete assembly (for 1500A units)
106023	Wand, Pick-up Probe, 36" Long, 1 1/4" OD Tube, Aluminum
106033	1 1/2" pick-up wand
108840	1 1/2" I.D. loader hose
108207	1" to 2" worm gear clamp
137590	Retro Fit Kit 1250 - 1500 (to convert an old loader with an 070 pbc board to the PLC controller)
137591	Retro Fit Kit VP – PL (to convert an old loader with an 070 pbc board to the PLC controller)
137592	Retro Fit Kit PLVP (to convert an old loader with an 070 pbc board to the PLC controller)

NOTE: In 2006, IMS upgraded its loaders from boards to modules. These modules are self-contained and when installed correctly will eliminate dust and static wire issues.



Returns

Should your Loader or any of its components require service or replacement, contact the factory for a Return Material Authorization (**RMA**) number prior to returning items. A return should only be executed after exhausting all possible remedies outlined in the Troubleshooting section, or attempts to remedy as instructed by customer service technical staff.

Prior to contacting IMS have the unit's model number and serial number (located on the Loader's mounting flange) and any other information relating to the specific order available when calling. For proper receiving and tracking, please ensure that all accompanying paperwork references your assigned RMA number.

Thank you for choosing IMS Company for your material handling needs, if you should have any further questions as to the operation of this unit or any other IMS product please contact Customer Service at (440) 543-1615 or (800) 537-5375, Monday thru Friday between the hours of 8:00 AM and 6:00 PM Eastern Time.

Item #	Part #	Description
1	118782	Motor Cover (No Connector Holes)
2	123471	Lid with latches and gasket
3	121041	Body assembly
4	105969	Dump valve assembly
5	105986	Standard nylon filter
5	106036	Standard polyfelt filter
6	106002	Rubber filter gasket
7	120756	Latch, body
8	106031	Receptacle, 5 conductor
9	120724	Cord, 5 conductor, 3' long
10	127400	Cord grip, 90 degree
11	106021	Motor and Fan
12	120489	Cord grip
13	116050	Cord, micro, 3 conductor, prox switch
14	109112	Power cord
15	116177	Control panel assembly
16	118853	Control board
17	116286	Proximity switch
18	120299	Latch, motor cover
19	117362	Gasket, motor
20	108319	Counterweight
21	118589	Switch - on/off, circuit breaker type
22	112443	Light, convey indicator (amber)
23	129276	Light, power indicator (red)
24	129277	Light, service indicator

1. ALL DIMENSIONS ARE IN INCHES.

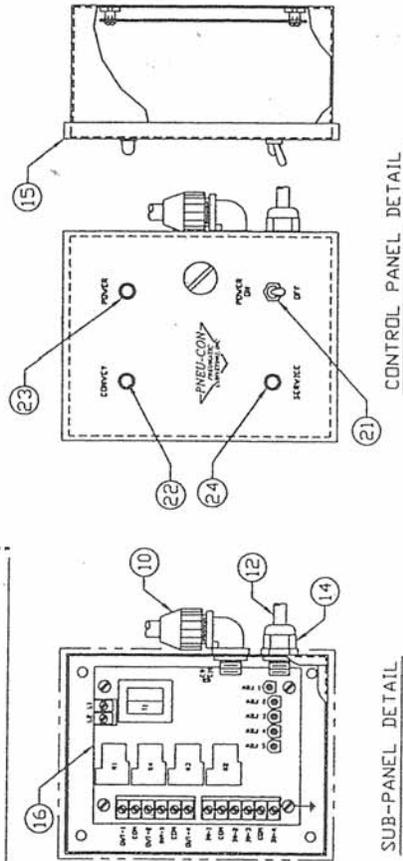
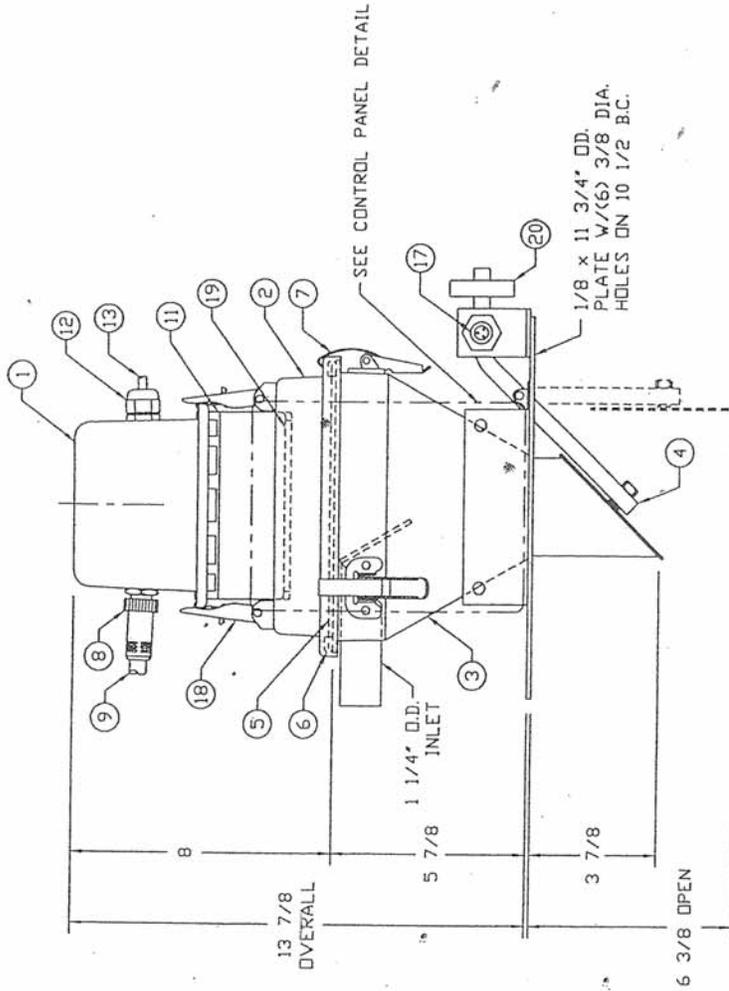

Item #	Part #	Description
1	118782	Motor Cover (No Connector Holes)
2	120669	Lid with latches and gasket
3	121041	Body assembly
4	105969	Dump valve assembly
5	105986	Standard nylon filter
5	106036	Standard polyfelt filter
6	106002	Rubber filter gasket
7	120756	Latch, body
8	114245	Receptacle, 6 conductor
9	120815	Cord, 6 conductor, 3' long
10	127400	Cord grip, 90 degree
11	106021	Motor and Fan
12	120489	Cord grip
13	116050	Cord, micro, 3 conductor, prox switch
14	109112	Power cord
15	117291	Control panel assembly
16	118853	Control board
17	116286	Proximity switch
18	120299	Latch, motor cover
19	127402	Flex conduit connector (w/conduit)
20	none	Flex conduit
21	109117	Solenoid valve
22	none	Flex conduit connector, straight
23	119319	Polyflow fitting 1/4 - 3/8
24	117362	Gasket, motor
25	108319	Counterweight
not shown	118589	Switch - on/off, circuit breaker type
not shown	112443	Light, convey indicator (amber)
not shown	129276	Light, power indicator (red)
not shown	129277	Light, service indicator

NOTES:
1. ALL DIMENSIONS ARE IN INCHES.

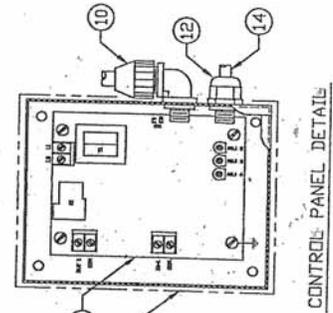
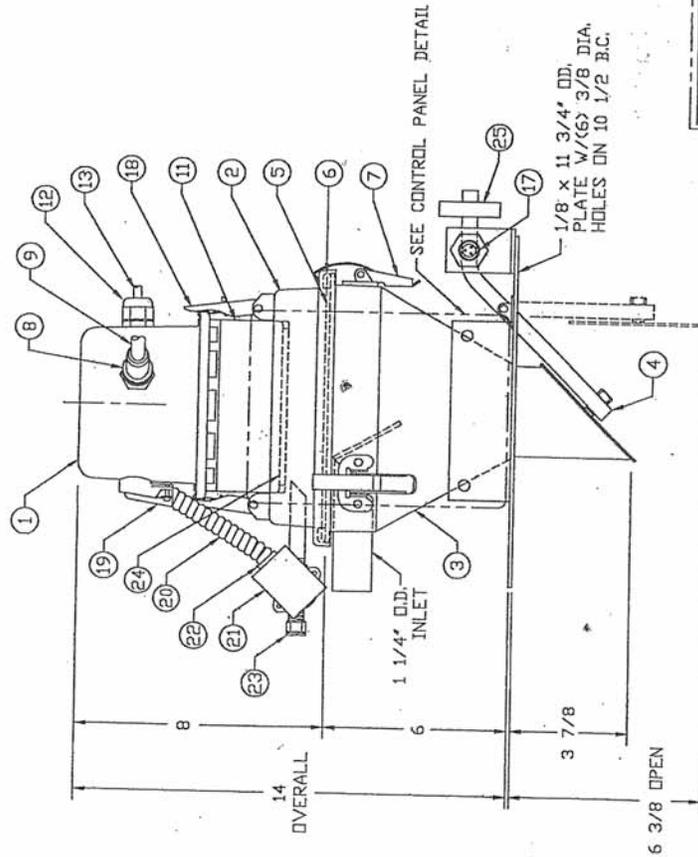

Item #	Part #	Description
1	118782	Motor Cover (No Connector Holes)
2	120669	Lid with latches and gasket
3	128239	Body assembly
4	105969	Dump valve assembly
5	105986	Standard nylon filter
5	106036	Standard polyfret filter
6	106002	Rubber filter gasket
7	120756	Latch, body
8	107656	Receptacle, 7 conductor
9	none	Cord, 7 conductor, 3' long
10	127400	Cord grip, 90 degree
11	106021	Motor and Fan
12	120489	Cord grip
13	116050	Cord, micro, 3 conductor, prox switch
14	109112	Power cord
15	117292	Control panel assembly
16	148863	Control board
17	116286	Proximity switch
18	120299	Latch, motor cover
19	127402	Flex conduit connector (w/conduit)
20	none	Flex conduit
21	109117	Solenoid valve
22	109127	Air Cylinder
23	118050	1/4" poly flow tubing
24	none	1/4" poly bulk head fitting
25	117942	1/4" poly flow fitting
26	none	1/4" x 3/8" poly flow fitting, 90 deg
27	106056	solenoid valve (4) way
28	117362	Gasket, motor
29	108319	Counterweight
not shown	none	Flex conduit connector, straight
not shown	118589	Switch - on/off, circuit breaker type
not shown	112443	Light, convey indicator (amber)
not shown	129276	Light, power indicator (red)
not shown	129277	Light, service indicator
not shown	112065	Proportional knob
not shown	106055	Proportional potentiometer
not shown	109089	Plastic seal for proportional cylinder

NOTES:
1. ALL DIMENSIONS ARE IN INCHES.

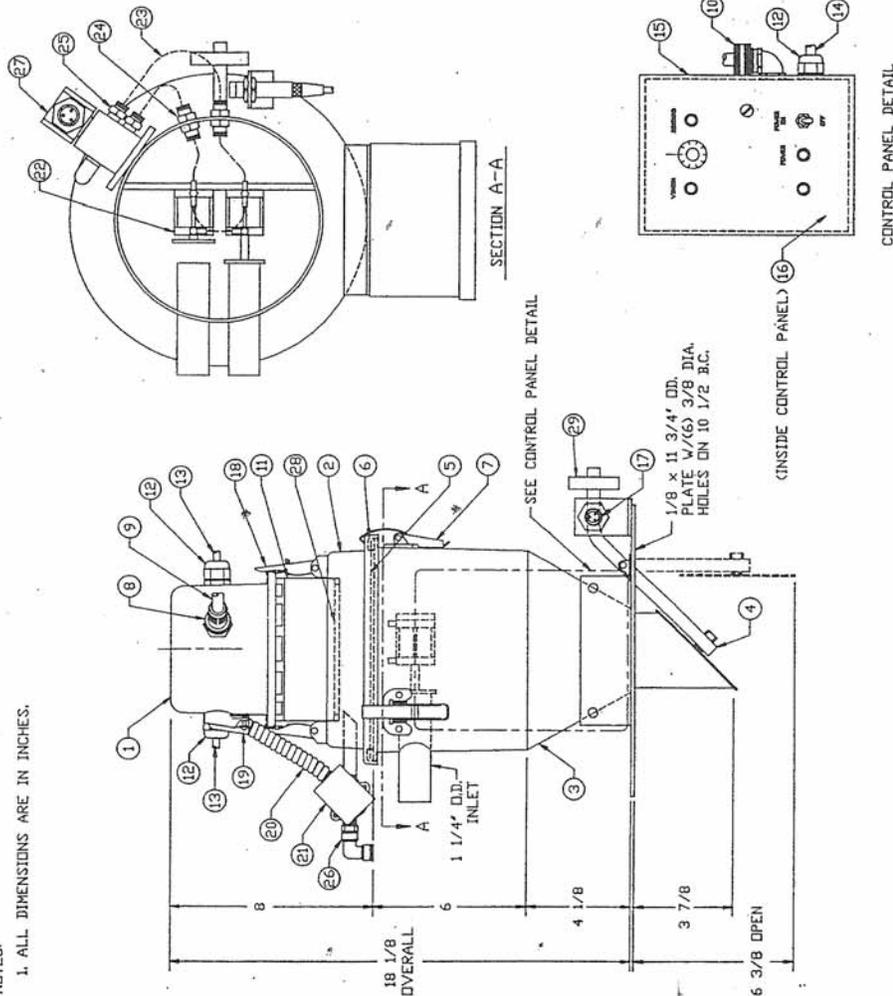

ITEM NO	IMS PIN	DESCRIPTION
1	109106	Lid w/Sound Hood and Latches
2	105977	Filter, 14" Nylon
3	105990	Gasket for Filter, 14"
4	124070	Receiver Body Assembly w/Hood Latches & Flange
5	117150	Latch, Body
6	105981	Dump Valve Assembly
7	118782	Motor Cover, No Connectors or Holes
8	106014	Cord, Control Box to Motor 5 Conductor (Pin)
9	106031	Motor Hood Control Cord Connector, 5 Conductor (Pin)
10	116050	Cord, Proximity Switch, 3 Conductor (Pin)
11	120489	Cord Grip, Strain Relief
12	116286	Proximity Switch
13	126887	Latch, Motor Cover
14	106021	Vacuum Motor
15	117362	Gasket, Motor - Black Neoprene
16	105922	Counterweight for Dump Valve
17	106033	Pickup Probe, 36" Long x 1-1/2" OD
18	109112	Power Cord for Control Box, Black
19	105987	Brush Kit, for Vacuum Motor
20	121325	Control Box, Entire Assembly
21	137590	PLC Controller for Control Box

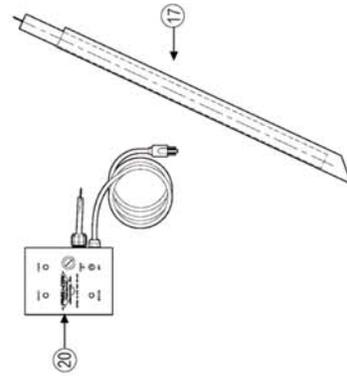
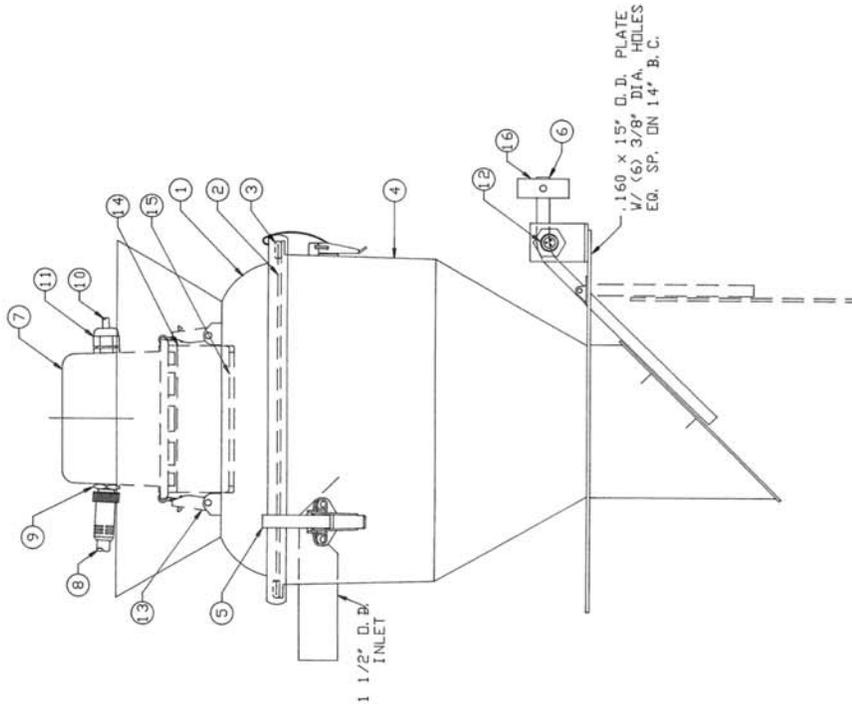

Model 1500A

Model 1500VPA Vacuum Loader		
ITEM NO	IMS P/N	DESCRIPTION
1	105978	Lid w/Sound Hood and Latches
2	105977	Filter, 14" Nylon
2A	106026	Filter, 14" Polyester Felt
3	105990	Gasket for Filter, 14"
4	124070	Receiver Body Assembly w/Hood Latches & Flange
5	117150	Latch, Body
6	105981	Dump Valve Assembly
7	118782	Motor Cover, No Connectors or Holes
8	109118	Cord, Control Box to Motor 6 Conductor (Pin)
9	114245	Motor Hood Control Cord Connector, 6 Conductor (Pin)
10	116050	Cord, Proximity Switch, 3 Conductor (Pin)
11	106031	Cord Grip, Strain Relief
12	116286	Proximity Switch
13	126887	Latch, Motor Cover
14	106021	Vacuum Motor
15	119393	Pulse Valve Assembly (Includes Solenoid)
16	109113	Pulse Bottle
17	140307	Turbo Solenoid Coil for Pulse Valve
18	117362	Gasket, Motor - Black Neoprene
19	105922	Counterweight for Dump Valve
20	106033	Pickup Probe, 36" Long x 1-1/2" OD
21	109112	Power Cord for Control Box, Black
22	105987	Brush Kit, for Vacuum Motor
23	123968	Control Box, Entire Assembly
24	137591	PLC Controller for Control Box
25	138078	Programming Chip For PLC Controller

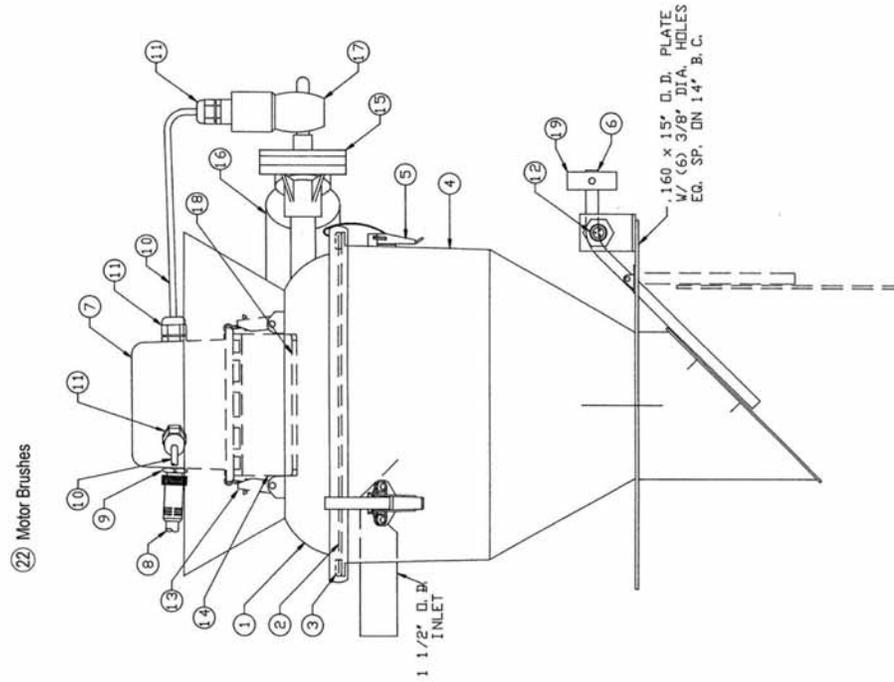
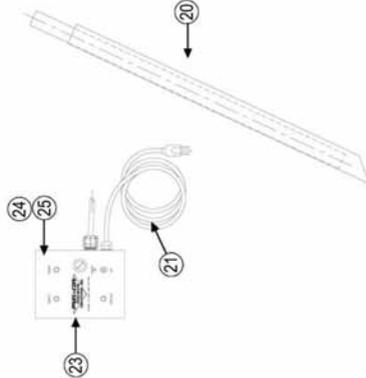

Model 1500VPA

1500 PLVP-A
WHISPER LOADER

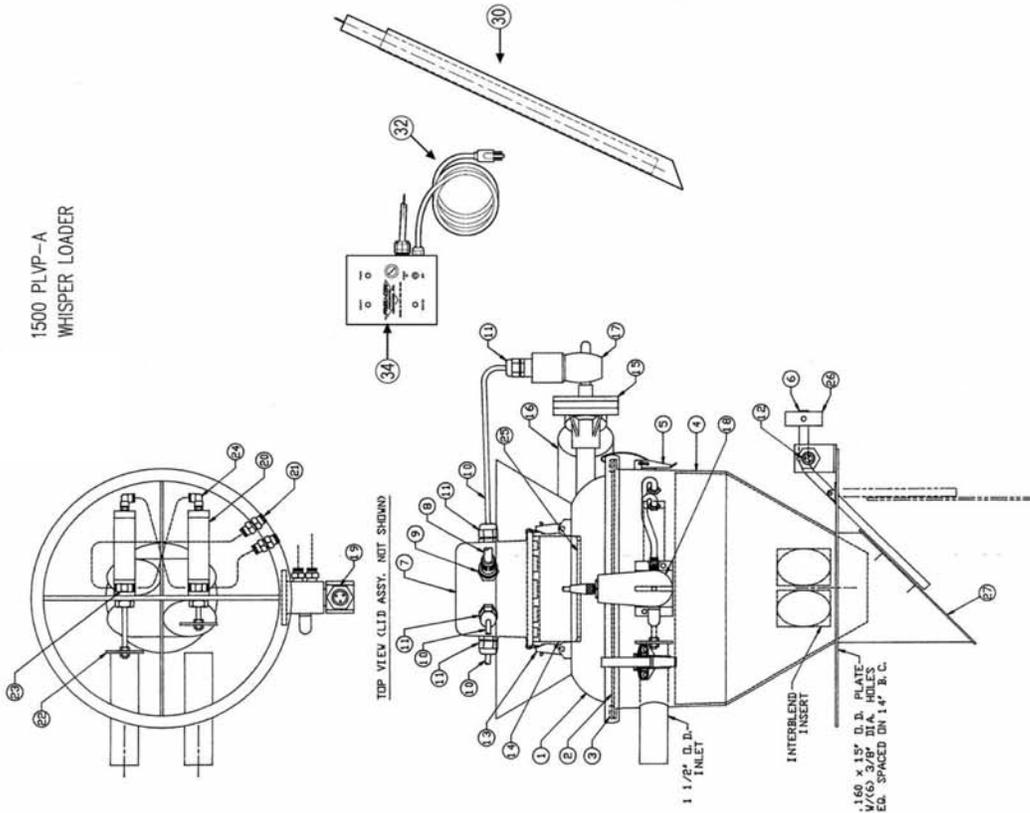

Model 1500PLVPA Vacuum Loader

ITEM NO	IMS P/N	DESCRIPTION
1	105978	Lid w/Sound Hood and Latches
2	105977	Filter, 14" Nylon
2A	106026	Filter, 14" Polyester Felt
3	105990	Gasket for Filter, 14"
4	124070	Receiver Body Assembly w/Hood Latches & Flange
5	117150	Latch, Body
6	105981	Dump Valve Assembly
7	118782	Motor Cover, No Connectors or Holes
8	106714	Cord, Control Box to Motor 7 Conductor (Pin)
9	107656	Motor Hood Control Cord Connector, 7 Conductor (Pin)
10	116050	Cord, Proximity Switch, 3 Conductor (Pin)
11	120489	Cord Grip, Strain Relief
12	116286	Proximity Switch
13	126887	Latch, Motor Cover
14	106021	Vacuum Motor
15	119393	Pulse Valve Assembly (Includes Solenoid)
16	109113	Pulse Bottle
17	140307	Turbo Solenoid Coil for Pulse Valve
18	106056	Solenoid Valve for Proportioning Cylinders
19	122050	Receptacle, 3 Conductor (Pin) for Proportioning Solenoid
20	114186	Air Cylinder
21	119319	1/4" Tubing Fitting, 1/4" NPT Bulk Head Thread
22	119984	Proportioning Port Plug, Rubber (Formerly a plastic disc)
23	117927	1/4" Tubing Fitting, TEE, 1/8" NPT Thread for Cylinder
23A	117922	1/4" Tubing Fitting, TEE, 1/4" NPT Thread for Solenoid (Not shown)
23B	117917	3/8" Tubing Fitting, TEE, 1/4" NPT Thread for Solenoid (Not shown)
24	117934	1/4" Tubing Fitting, 90 Deg ELBOW, 1/8" NPT Thread for Cylinder
25	117362	Gasket, Motor - Black Neoprene
26	105922	Counterweight Only for Dump Valve Assembly
27	105970	Flapper Only for Dump Valve Assembly
28	108840	1-1/2" ID Flexible Static Wire Vacuum Hose (Not shown)
29	135764	Hose Clamp, Spiral Double Bolt Style (Not shown)
30	106033	Pickup Probe, 36" Long x 1-1/2" OD
31	106088	Air Regulator w/Filter (Not shown)
32	109112	Power Cord for Control Box, Black
33	105987	Brush Kit, for Vacuum Motor (Not shown)
34	109076	Control Box, Entire Assembly
35	137592	PLC Controller Retrofit Kit for Control Box (Not shown)
35A	142841	PLC Controller Only (Not shown)
36	138079	Programming Chip For PLC Controller (Not shown)

Model 1500PLVPA

Model PL1250 Powder Vacuum Loader		
ITEM NO	IMS P/N	DESCRIPTION
1	118782	Motor Cover, No Connectors or Holes
2	120671	Lid Assy with Motor Latches, Gasket and Tube
3	135261	Receiver body assembly
4	105969	Dump Valve Assembly
5	120065	Filter, replacement, Pleated
6	106002	Gasket, 9" Diameter
7	120756	Latch, Body
8	114245	Motor Housing Connector
9	109118	Interconnect Cord, Motor to Control Box
10	none	Use Proximity Cord #116050
11	106021	Vacuum Motor with Fan
12	120489	Cord Grip
13	116050	Proximity Switch Cord
14	119393	Pulse Valve Assembly
15	126772	Tube Sheet, Single Cartridge, 9" Diameter
16	109113	Air Bottle, 6"
17	128044	Bellows Boot
18	116286	Proximity Switch
19	108319	Counterweight for Dump Valve
20	117362	Gasket for Lid Assy/Motor
21	120299	Latch, Motor Cover
22	129277	Power Light, Red
23	109112	Power Cord, Black
24	144670	Electrical Control Box/Panel
25	137591	PLC Controller
26	129276	Service Light, Red
27	118589	Toggle Switch - On/Off
28	112443	Convey Light, Amber

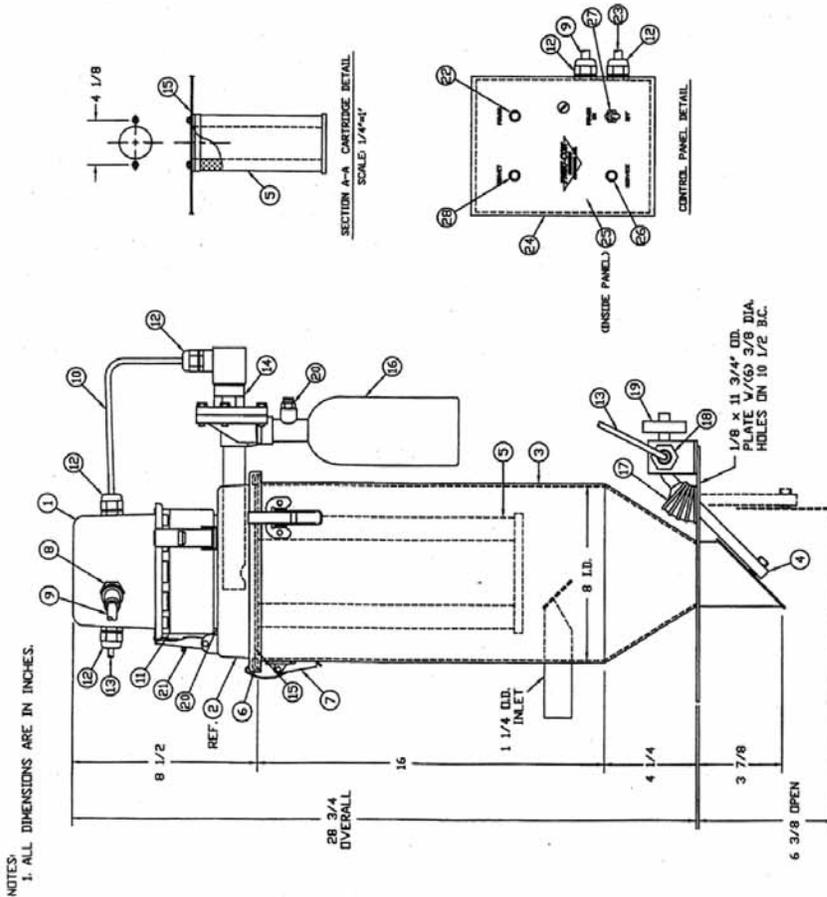

Model PL1250

ITEM NO	IMS PIN	DESCRIPTION
1	118782	Motor Cover, No Connectors or Holes
2	124058	Lid Assy with Motor Latches, Gasket and Tube
3	143652	Receiver body assembly
4	105981	Dump Valve Assembly
5	120065	Filler, replacement. Pleated
6	105990	Gasket, 14" Diameter
7	117150	Latch, Body
8	114245	Motor Housing Connector
9	109118	Interconnect Cord, Motor to Control Box
10	none	Use Proximity Cord #116050
11	106021	Vacuum Motor with Fan
12	120489	Cord Grip
13	116050	Proximity Switch Cord
14	119393	Pulse Valve Assembly
15	124744	Tube Sheet, Three Cartridge, 14" Diameter
16	121157	Air Bottle, 12"
17	128044	Bellows Boot
18	116286	Proximity Switch
19	105992	Counterweight for Dump Valve
20	117362	Gasket for Lid Assy/Motor
21	120299	Latch, Motor Cover
22	129277	Power Light, Red
23	109112	Power Cord, Black
24	144670	Electrical Control Box/Panel
25	137591	PLC Controller
26	129276	Service Light, Red
27	118589	Toggle Switch - On/Off
28	112443	Convey Light, Amber
29	122746	Sound Hood Assembly

NOTES:
1. ALL DIMENSIONS ARE IN INCHES.

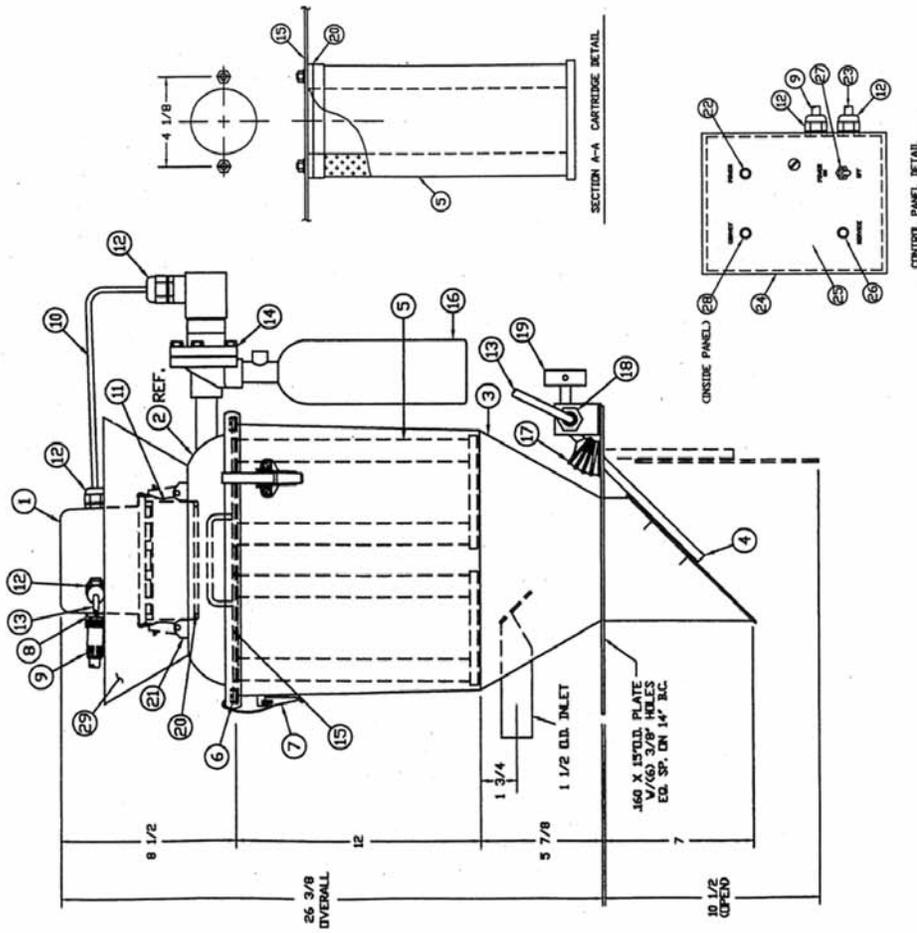

Model PL1500



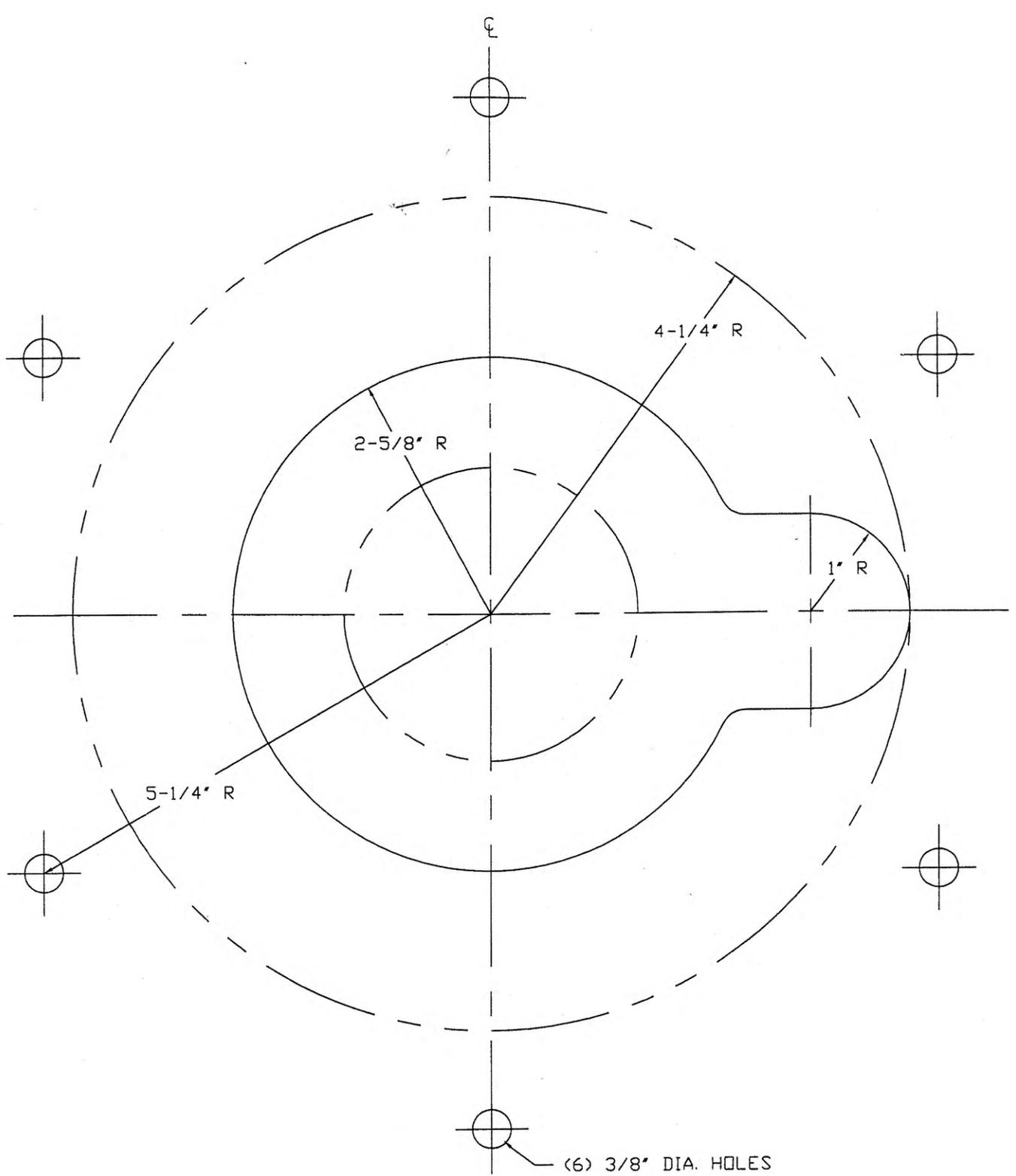

TITLE				MOUNTING TEMPLATE - SC1250			
FOR							
DRAWN BY		RS	DATE		3/19/93	PART NO.	
CHECKED						SCALE	FULL
APPROVED						DWG. NO.	PC5751

REVISIONS			
LTR	DESCRIPTION	BY	DATE
A	1ST DLR. DDL VAE 10-1/8"	RS	6/14/86

15' O.D. SC1500
& SC1750 FLANGE

(6) 3/8" DIA. HOLES
EQ. SP. ON 14" B.C.

3 5/8" R
MIN. CIRCLE

5 5/8" R
RECOMMENDED
MAX. CIRCLE

1" R

TITLE			
MOUNTING TEMPLATE FOR SC1500, SC1750			
FOR			
DRAWN BY	HF	DATE	6/26/86
CHECKED			
APPROVED			
SCALE		FULL	
DRAWING NO.		PC5754	